



Nomad Lock-Up Kit Installation Instructions

Suitable for:



**Toyota Prado 150 Series with
AC60 6 Speed Auto**

WITH THE FOLLOWING ENGINES:
1GD-FTV 2.8L Turbo Diesel (06/2015 to Present)

Please read through all of the instructions carefully before proceeding. If any of the information does not appear correct or the diagrams don't match your vehicle, please contact Wholesale Automatic Transmissions or your place of purchase.

Table of Contents

1. Parts List	3
2. Information to note prior to starting	4
2.1. Electrical Safety.....	4
2.2. Identifying the Nomad Lock-Up Kit Parts.....	5
3. Installing the Nomad Lock-Up Kit	7
3.1. Recommended Mounting Location	7
3.2. Installing the Harness in the Cabin - Passenger Side	8
3.3. TCM Wiring	11
3.4. TCM Wiring Diagram.....	12
3.5. Mounting Nomad Module and Resistor	15
3.6. Installing the Harness in the Cabin - Drivers Side	17
3.7. CAN Bus Wiring Installation	18
3.8. TCC Switch Installation.....	20
3.9. Final Tidy Up	21
3.10. Lock-Up Module Bypass.....	22
3.11. Installing the Nomad LockUp app on Apple Devices	23
3.12. Troubleshooting Installation on Apple Devices.....	25
3.13. Installing the Nomad LockUp app on Android™ Devices	27
3.14. Troubleshooting Installation on Android Devices	29
4. Setup Wizard	31
4.1. First Connection and Firmware Update	31
4.2. Vehicle Configuration.....	33

1. Parts List

Nomad Lock-Up
ModuleNomad Lock-Up
Main HarnessPrado OEM Style
Momentary SwitchOEM Switch Loom
Adapter to suit Prado

Resistor Loom - 6D

Toyota CAN Bus Interface
LoomModule Bypass
Connector2 x Long Metal Self
Tapping Screws2 x Short Metal Self
Tapping Screws4 x 30mm Pieces of
Black Heatshrink

20 x Cable Ties

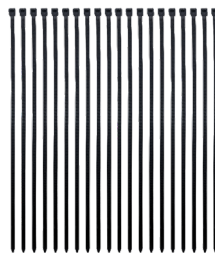

Getting Started Manual

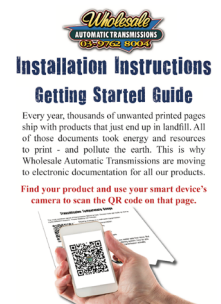

Estimated Install Time: 2 Hours

2. Information to note prior to starting

2.1. Electrical Safety

- 2.1.1 Disconnect all vehicle power sources including batteries, chargers and solar systems before starting the installation process.
- 2.1.2 The Load Resistor **MUST** be mounted to a metal surface clear of carpet, plastic or any material that could be damaged by heat. This resistor can reach temperatures over 50°C while in operation.



- 2.1.3 You can mount the Nomad module anywhere inside or outside the vehicle. The Nomad Module is IP68 rated so it can be mounted in the engine bay, however it must be away from heat sources such as turbos, exhausts and the engine block.

Also, take into consideration that the further away from the driver the module is mounted the lower the Bluetooth signal strength will be.

We recommend mounting the Nomad module inside the cabin.



- 2.1.4 The installation of this kit requires the fitter to have good knowledge of 12 volt wiring, an understanding of wiring schematics and good experience with soldering wires together. If you don't feel comfortable doing any of these tasks, then please contact one of our local Authorised Fitting Agents or your local Auto Electrician to have the unit installed professionally.

2.2. Identifying the Nomad Lock-Up Kit Parts

- 2.2.1 There are four (4) legs on the Nomad Lock-Up Harness (TCLU-HARNESS) that you need to be aware of. These legs define the purpose of the wires contained within.

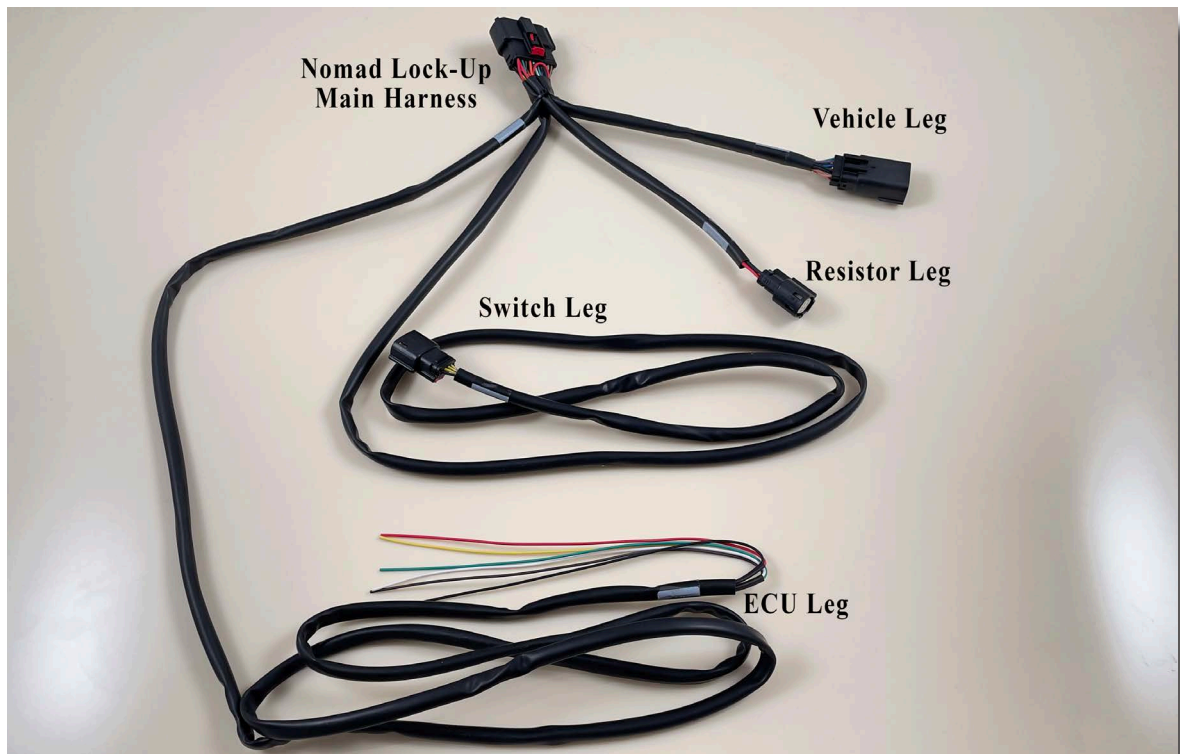

2.2.2 ECU Leg

This leg contains the wires that will be wired into the OEM Transmission Control Module (TCM). These wires connect to the Lock-Up Solenoid inside the transmission as well as picking up 12v+ Switched Power and Ground. If you feel there is too much wire on the ECU leg it can be trimmed back to a more suitable length. Just be conservative with your trimming as we don't recommend extending these wires.

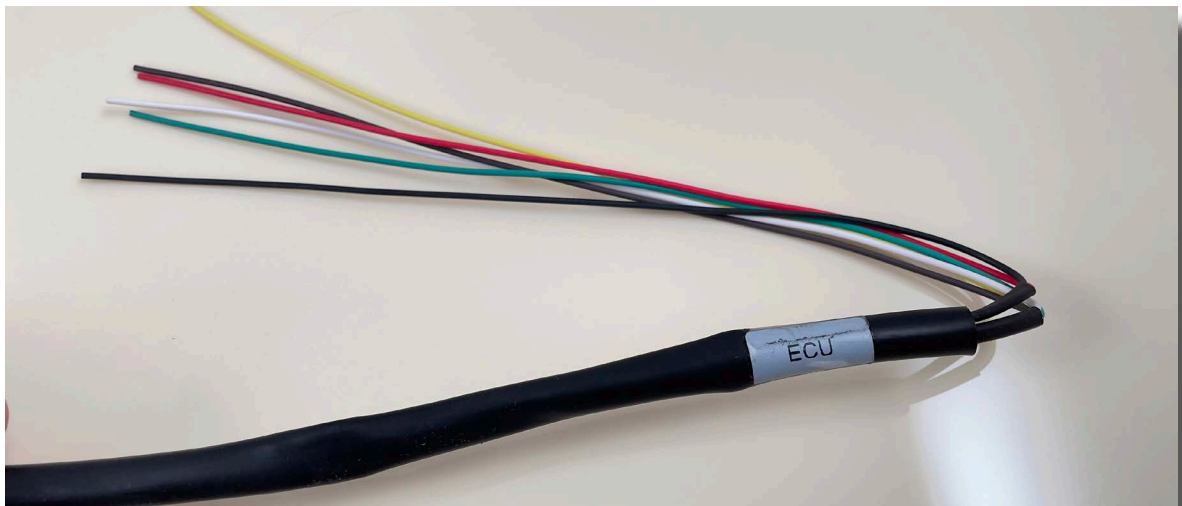

2.2.3 Switch Leg

This leg runs to where you plan to install the manual lock-up switch. This may use either a OEM style push switch or a Carling style rocker switch, depending on your vehicle's dash configuration.

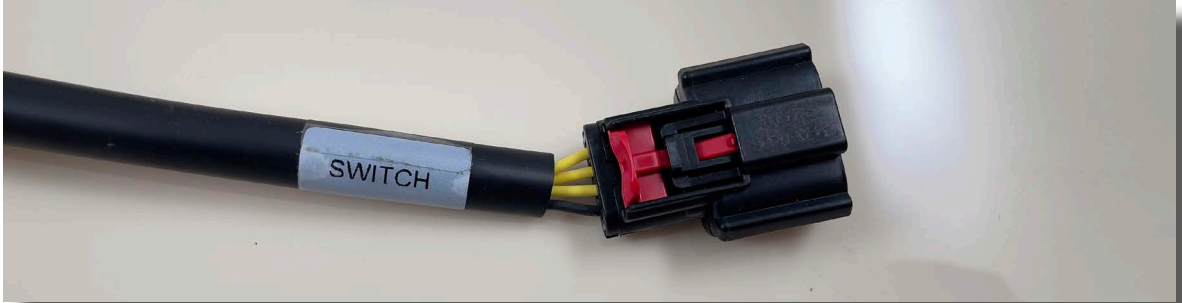

2.2.4 Resistor Leg

The resistor leg is one of the smaller legs of the Nomad harness. It provides a universal connection to the load resistor. This load resistor will vary depending on the transmission the Nomad Lock-Up Kit is controlling.



2.2.5 Vehicle Leg

Lastly, the vehicle leg. This leg is for the wires that will connect to various signals in your vehicle, depending on what vehicle you are installing the Nomad Lock-Up kit into. This may include Throttle Position Sensors (TPS), Vehicle Speed Sensors (VSS), or the vehicle's internal CAN bus.

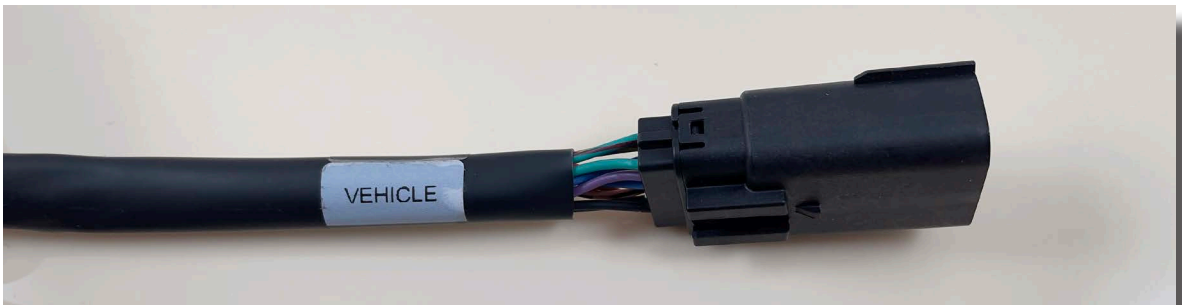

3. Installing the Nomad Lock-Up Kit

3.1. Recommended Mounting Location

- 3.1.1 While you are free to mount the various parts of the Nomad Lock-Up kit anywhere in your vehicle that you feel is the most appropriate, the installation instructions will assume you are mounting the parts in our recommended locations.

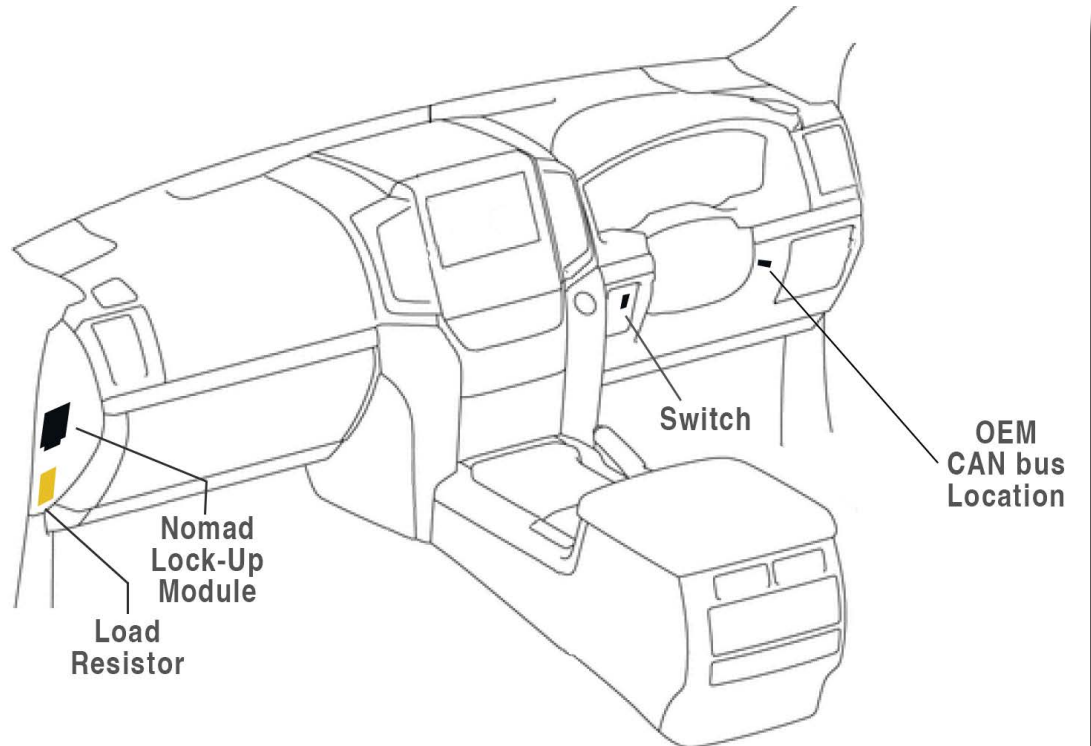

3.2. Installing the Harness in the Cabin - Passenger Side

****Disconnect all vehicle power sources including batteries, chargers and solar systems before starting the installation process.****

The resistor is used to dissipate energy from the OEM TCM. As such, the resistor will get hot when the Nomad Lock-Up system is operating. This is expected behavior.

The resistor **MUST** be mounted to a flat, metal surface to aid in heat dissipation. It may cause damage to plastic or carpet these materials come in contact with the resistor.

In the Toyota Prado 150 Series we have found a good location for the load resistor is on the passenger footwell inner wall, up high near the glove box. This allows ample space around the resistor to prevent its heat from damaging anything.

There is also space in this area to mount the Nomad module. Ultimately, however, this decision will be up to the installer as we are not able to account for accessories or slight variations in your model.

- 3.2.1 Start by removing the glove box. This is held in with two tabs on the side of the glove box, which can be released by squeezing in on both sides of the glove box gently and pulling forwards until the glove box releases. You will also need to release the soft opening mechanism on the left hand side. Finally, lift the glove box off the lower hinges.
- 3.2.2 Remove the single screw that secures the upper kick panel. Remove the kick panel.

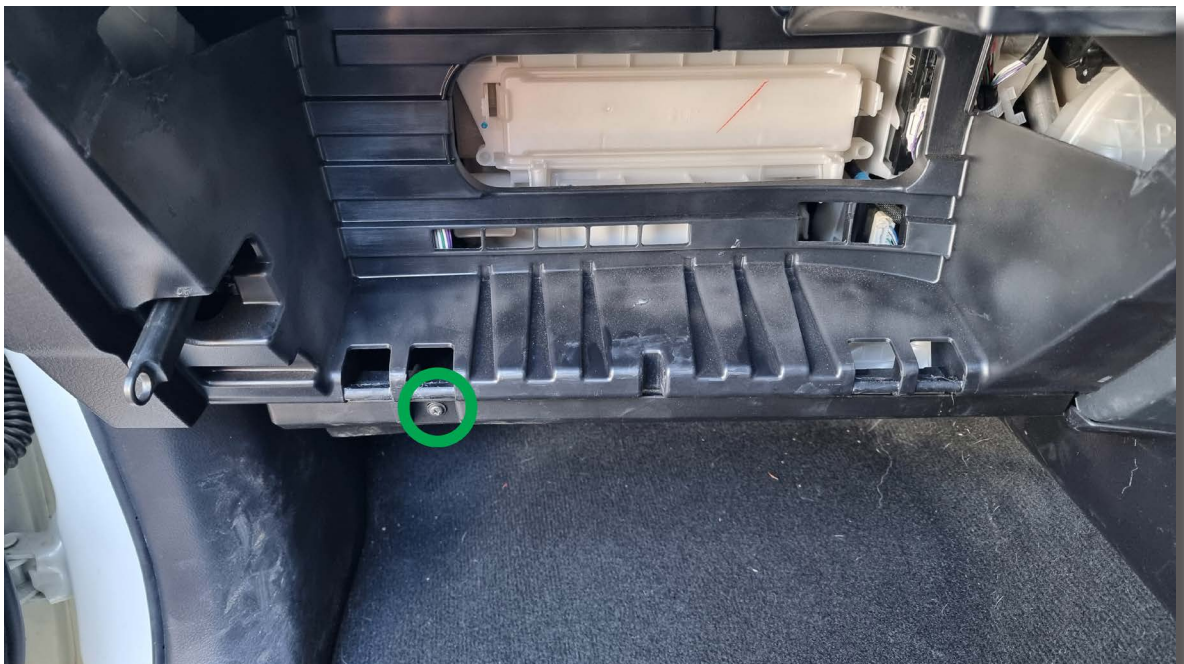

- 3.2.3 Remove the lower left kick panel on the passenger side. This requires removing a plastic nut at the back of the foot well as well as prying up the plastic sill protector on the floor next to the seat. Once these two pieces are out of the way the panel can be carefully removed by pulling it towards the rear of the vehicle. There is a clip hidden behind this panel at the top that helps hold it in position.



- 3.2.4 Gently pry the dash side panel away from the dash board. Use plastic trim removal tools to avoid damaging the dashboard.



- 3.2.5 Remove the glove box garnish. This is held in with 5 clips along its length. Pry from the bottom and use plastic trim tools to prevent the decorative trim piece and the dashboard from being scratched or damaged.



- 3.2.6 Remove the 4 bolts holding in the glove box surround- two at the top and two at the bottom. Remove the glove box surround.

Be aware of the wiring for the glove box light. This is hidden at the top of the glove box surround, and can be accessed only after partially removing the surround. Disconnect this wiring before completely removing the glove box surround.



3.3. TCM Wiring

- 3.3.1 The Transmission Control Module (TCM) is mounted vertically near the blower motor and has 6 connectors plugged into it. Make sure there are no power sources connected to the vehicle (including auxiliary batteries and solar panels) before removing any of these connectors.

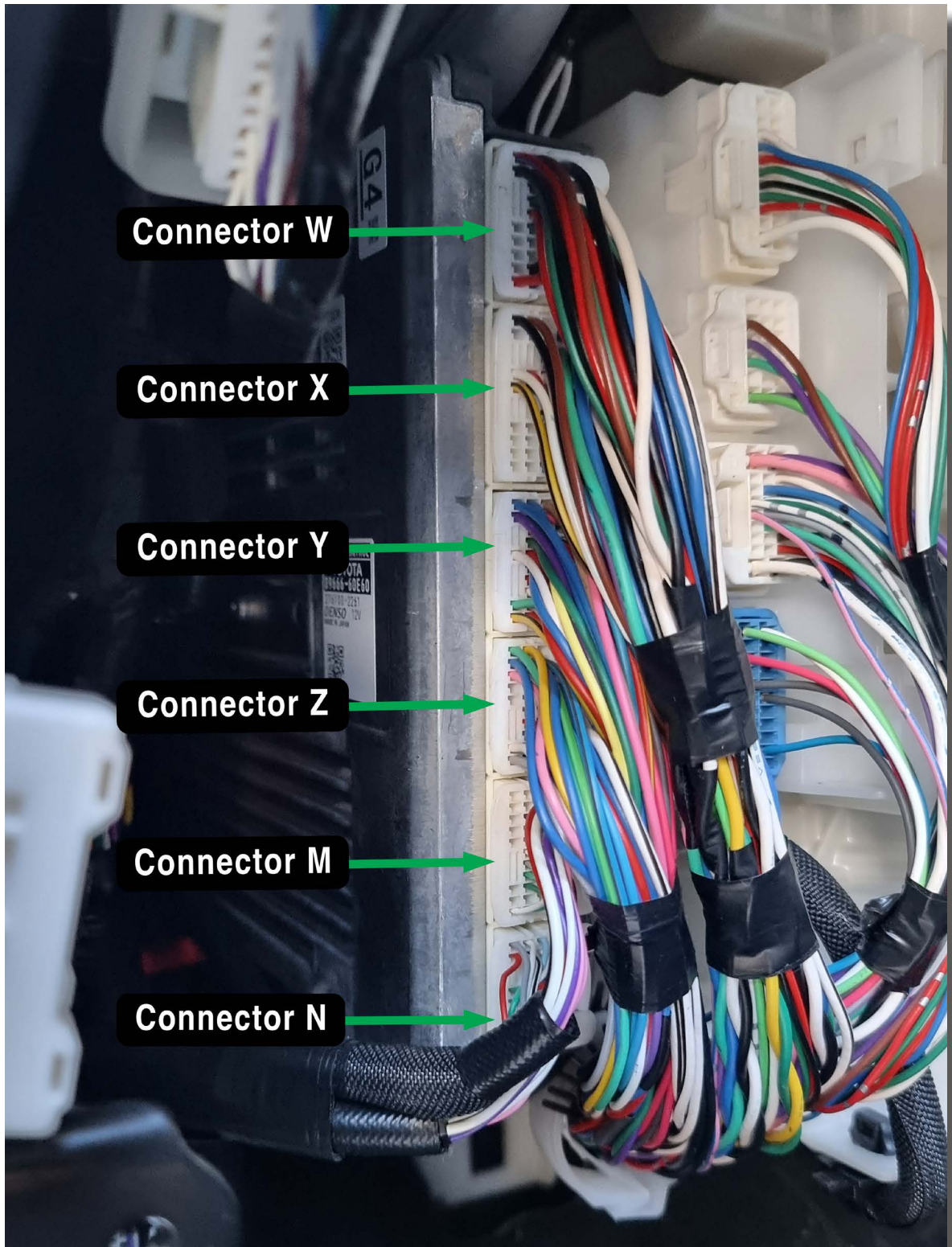

3.4. TCM Wiring Diagram

June 2015 - October 2024 - Prado 150 Series 2.8L Turbo Diesel Wiring Diagram

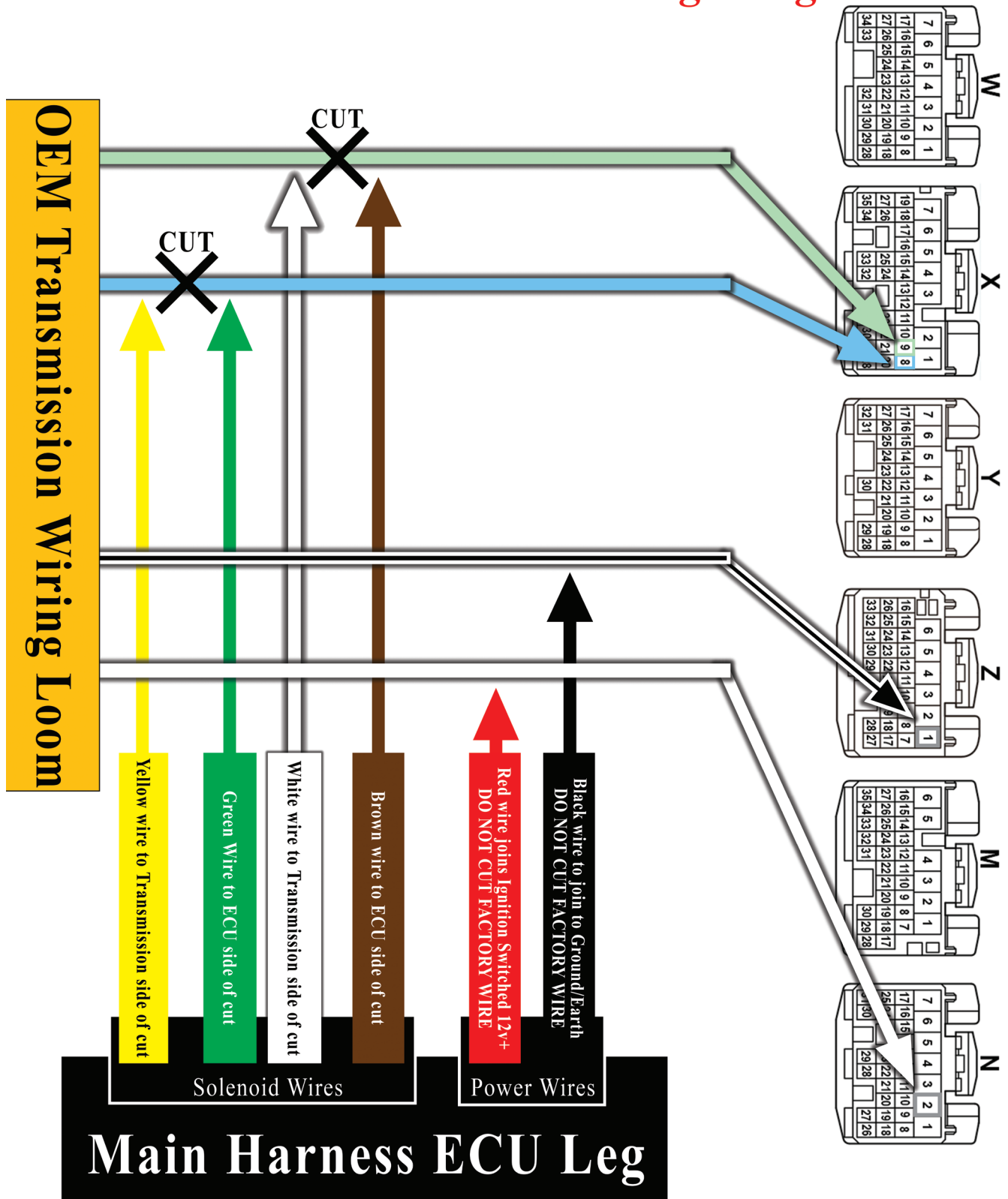

- 3.4.1 With all batteries disconnected, remove the connector labeled X from the TCM. Locate the two (2) OEM wires in pins X8 and X9 in the OEM connector as per the wiring diagram. Separate them from the rest of the wiring loom by using a cable ties or electrical tape if necessary.
- 3.4.2 Soldering to Solenoid Wire in X8**
- 3.4.2.1 Select the OEM wire in pin X8 and cut it approximately 5cm from the connector. Do not cut the second OEM wire in pin X9 yet.
- 3.4.2.2 Strip about 1cm of insulation from each wire to expose the copper.
- 3.4.2.3 Locate the Green wire in the Solenoid Wires group and slide one (1) piece of 2mm black heat shrink onto the wire.
- 3.4.2.4 Solder the Green wire to the TCM side of the OEM cut wire in pin X8. Slide the heat shrink over the join and use a heat source to shrink it.
- 3.4.2.5 Locate the Yellow wire in the Solenoid Wires group slide one (1) piece of 2mm black heat shrink onto the wire.
- 3.4.2.6 Solder the Yellow wire to the transmission side of the OEM cut wire in pin X8. Slide the heat shrink over the join and use a heat source to shrink it.
- 3.4.3 Soldering to Solenoid Wire in X9**
- 3.4.3.1 Select the OEM wire in pin X9 and cut it approximately 5cm from the connector.
- 3.4.3.2 Strip about 1cm of insulation from each wire to expose the copper.
- 3.4.3.3 In the Solenoid Wires group, locate the Brown wire, then slide one (1) piece of 2mm black heat shrink onto the wire.
- 3.4.3.4 Solder the Brown wire to the TCM side of the OEM cut wire in pin X9. Slide the heat shrink over the join and use a heat source to shrink it.
- 3.4.3.5 Locate the White wire in the Solenoid Wires group and slide one (1) piece of 2mm black heat shrink onto the wire.
- 3.4.3.6 Solder the White wire to the transmission side of the OEM cut wire in pin X9. Slide the heat shrink over the join and use a heat source to shrink it.
- 3.4.4 Reinstall the connector labeled X into the TCM.

3.4.5 Soldering to Ground Wire in Z1

- 3.4.5.1 Remove the connector labeled Z.
- 3.4.5.2 Locate the OEM wire in pin Z1.
- 3.4.5.3 Remove approximately 1cm of the wire sheath to expose the copper conductors about 5cm away from the connector. DO NOT cut this wire.
- 3.4.5.4 In the Power Wires group locate the Black wire and solder this wire to the OEM wire in pin Z1.
- 3.4.5.5 Use electrical tape to insulate the join and prevent shorting.
- 3.4.5.6 Reinstall the connector labeled Z into the TCM.

3.4.6 Soldering to Power Wire in N2

- 3.4.6.1 Remove the connector labeled N.
 - 3.4.6.2 Select the OEM wire in Pin N2.
 - 3.4.6.3 Remove approximately 1cm of the wire sheath to expose the copper conductors about 5cm away from the connector. DO NOT cut this wire.
 - 3.4.6.4 In the Power Wires group, locate the Red wire and solder this wire to the OEM wire in pin N2.
 - 3.4.6.5 Use electrical tape to cover the join to prevent shorting.
 - 3.4.6.6 Reinstall the connector labeled N into the TCM.
- 3.4.7 Use electrical tape and the included cable ties to secure the Nomad harness ECU Leg to the TCM wiring harness.
- 3.4.8 Please DO NOT use wire splicers, quick connects or scotch locks to join these wires. They MUST be soldered for reliable operation.



3.5. Mounting Nomad Module and Resistor

The best place we have found for mounting the Nomad module and the resistor is to the inner wall of the passenger footwell. This space provides ample clearance around the resistor and allows for easy access to the Nomad module if required, but ultimately the location of the Nomad module and resistor is not critical and it is up to the installers discretion as to where these components are mounted.

3.5.1 Secure the resistor using the two short self tapping screws provided.



3.5.2 Install the Nomad module to a flat section of the sheet metal footwell wall near the resistor. Ensure there is adequate clearance between it and the load resistor to prevent it from being affected by the hot resistor. Make sure it does not block any of the trim mounting locations. Secure with the two long self tapping screws provided.



- 3.5.3 Plug the resistor into the resistor leg of the Nomad harness and secure the red Connector Position Assurance (CPA).
- 3.5.4 Plug the main connector of the Nomad harness into the Nomad module and secure the red CPA.
- 3.5.5 Plug the Toyota CAN Bus Interface Loom into the Vehicle leg of the Nomad harness and secure the red CPA.
- 3.5.6 Route the Switch leg and Toyota CAN Bus Interface Loom up to the dash brace and along the brace towards the drivers side, securing with the supplied cable ties. Route these cables behind the stereo so they can be accessed from the drivers side.

We will go over accessing these cables in the next steps.

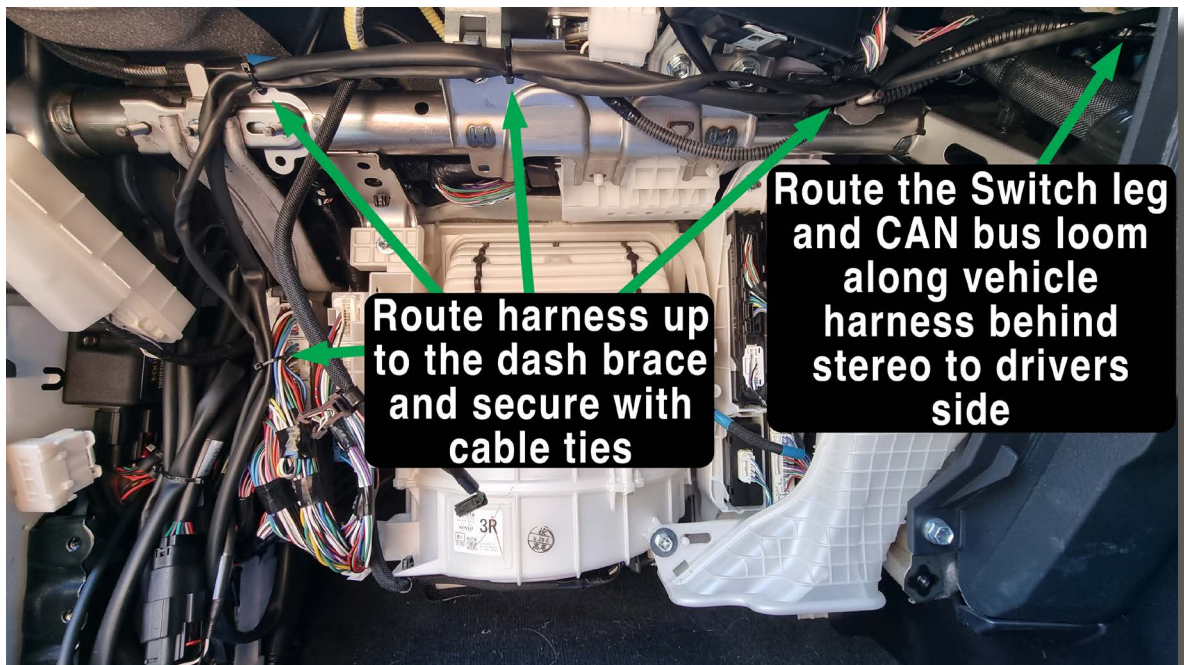

3.6. Installing the Harness in the Cabin - Drivers Side

- 3.6.1 Gently pry the dash side panel away from the dash board. Use plastic trim removal tools to avoid damaging the plastic.



- 3.6.2 Remove the lower right kick panel on the drivers side, using the same method outlined in step 3.2.3.
- 3.6.3 Use a small flat blade screw driver or pick to open the cover over the bolt holding in the lower dash panel on the left hand side. Remove this bolt, as well as the one on the lower right hand side of the lower dash panel. Remove the lower dash panel, being careful of the wiring going to the switches on the upper right hand side.



3.7. CAN Bus Wiring Installation

- 3.7.1 Pull through the Toyota CAN Bus Interface Loom that was routed behind the stereo earlier.
- 3.7.2 The CAN Bus connector we are needing to access is located behind the switches on the right hand side of the lower dash panel, and is mounted in a white receptacle.
- 3.7.3 Use a small screwdriver or pick to pry up on the locking tab to allow the CAN bus connector to be removed from its receptacle.
- 3.7.4 Turn over the connector to show the Terminal Position Assurance (TPA). Unlock the TPA by using a small pick or screwdriver to lift it up approximately 1mm. This will allow you to install the new terminals.

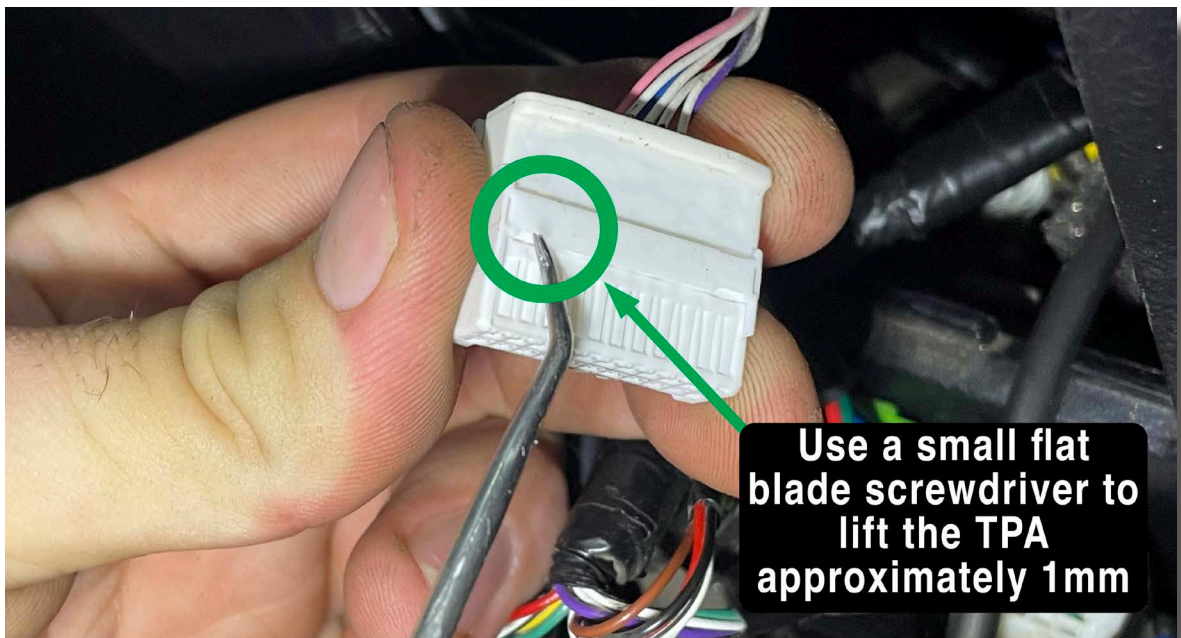

- 3.7.5 Insert the new terminals from the Toyota CAN Bus Interface Loom, with the locating tab aligned with the locating slot on the connector.

It is **CRITICAL** that the CAN bus wires are inserted with the correct polarity, but the wires can be inserted into any pair of terminal locations in the connector that are vertically aligned (directly above and below each other).

- 3.7.5.1 The Black wire from the Toyota CAN Bus Interface Loom must be inserted into the row with the multicolour OEM wires. Push the terminal in until you feel a slight click as the latch engages.
- 3.7.5.2 The White wire from the Toyota CAN Bus Interface Loom must be inserted into the row with the white OEM wires. Push the terminal in until you feel a slight click as the latch engages.

- 3.7.6 Re-seat the TPA by pushing it back into the connector until it is flush with the outer surface. The TPA should slide back in with little force- if you find you need to press hard to get it to seat first check that the terminals are fully seated into the connector.
- 3.7.7 Reinstall the CAN bus connector into its receptacle. Use some of the supplied cable ties to secure the CAN bus wiring, making sure it cannot get caught in any of the moving parts around the steering column.

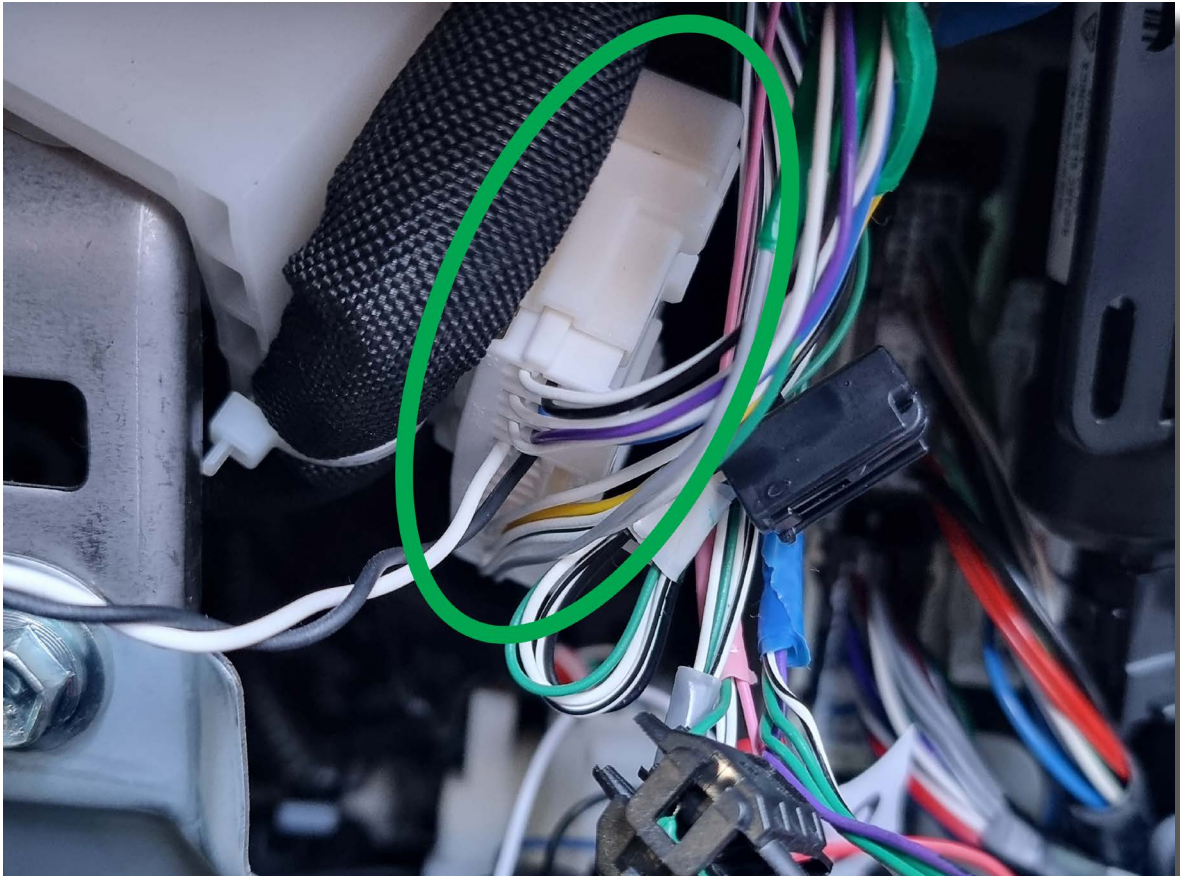

3.8. TCC Switch Installation

- 3.8.1 Pull through the Switch leg that was routed behind the stereo earlier. Route this cable towards the switch panel you would like the switch mounted in. We chose the switch panel on the left hand side, but you could choose to mount the TCC switch in a different switch panel.

The process to install the switch is the same for both the older and newer switch styles.

- 3.8.2 Use plastic trim removal tools to remove the switch panel from the dashboard, being careful not to scratch the dashboard.
- 3.8.3 Remove one of the switch blanks from the switch panel by pressing in on the locking tabs on either side. The switch blank can then be removed by pushing it out the front of the switch panel.

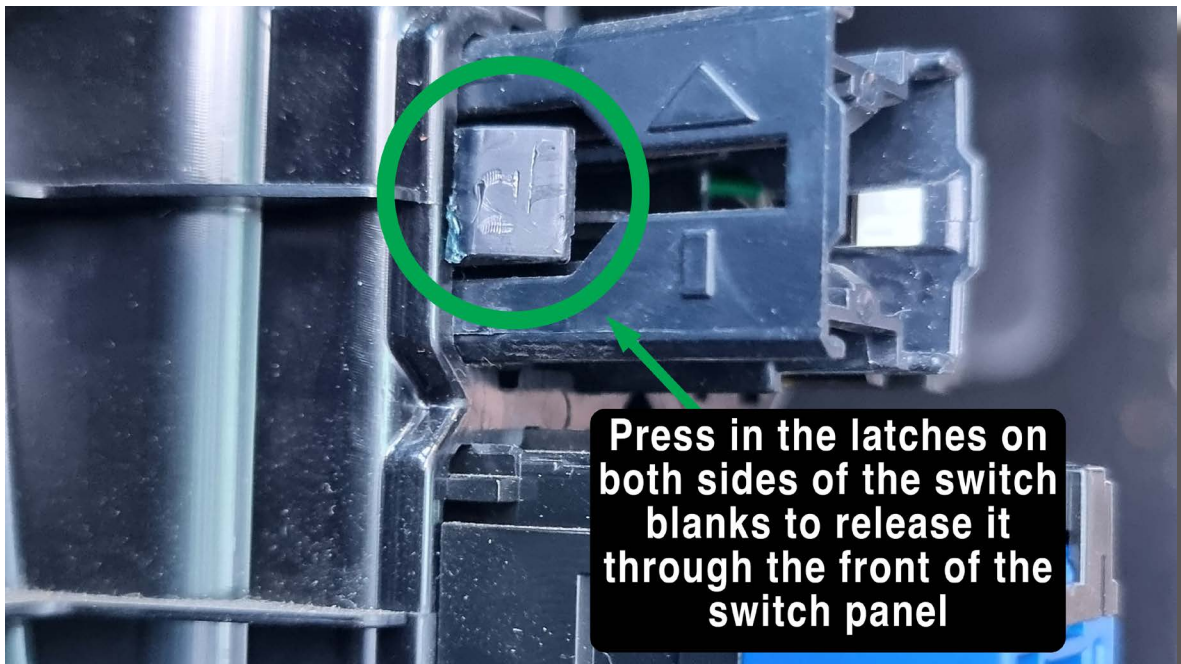

- 3.8.4 Feed the TCC switch into the switch panel through the front, pushing it in until the locking tabs click into place. Make sure the switch is in the correct orientation.
- 3.8.5 Plug the switch harness adapter into the connector on the back of the switch.
- 3.8.6 Plug the switch harness adapter into the Switch leg of the Nomad harness and secure the red CPA.
- 3.8.7 Reinstall the switch panel into the dashboard, lining up all the clips before pushing the panel into the dash. Use some of the supplied cable ties to secure the switch wiring, especially if it is near the steering column. Press the switch a few times to make sure it is free moving.

3.9. Final Tidy Up

- 3.9.1 Secure any loose wires with electrical tape and any remaining supplied cable ties. Make sure the wires are clear of any moving parts, especially near the steering column.
- 3.9.2 Reconnect the battery terminals and any other connectors that were removed.
- 3.9.3 We recommend running through the Nomad Setup Wizard to verify that everything is connected correctly and working properly before re-installing the any panels, just in case any wiring needs to be corrected.
- 3.9.4 Once the Nomad module has been confirmed to be wired correctly and the setup wizard has completed, reinstall all removed trim pieces and kick panels.

We do not recommend driving the vehicle before the setup wizard is complete.

3.10. Lock-Up Module Bypass

3.10.1 If you need to remove the Nomad Lock-Up Module at any stage we have supplied a bypass connector that can take the place of the module so that your vehicle will not have faults come up while driving. Fitting this bypass will revert control of the torque converter clutch back to the OEM TCM.

If you are fitting this unit on behalf of a customer please leave this connector in the bag along with the QR code to access the User Guide. Please highlight this to your customer during handover.



3.10.2 To remove the Nomad Lock-Up Module or Bypass Connector, unlock the red CPA. Press down on the black clip to release. Then pull the two connectors apart.

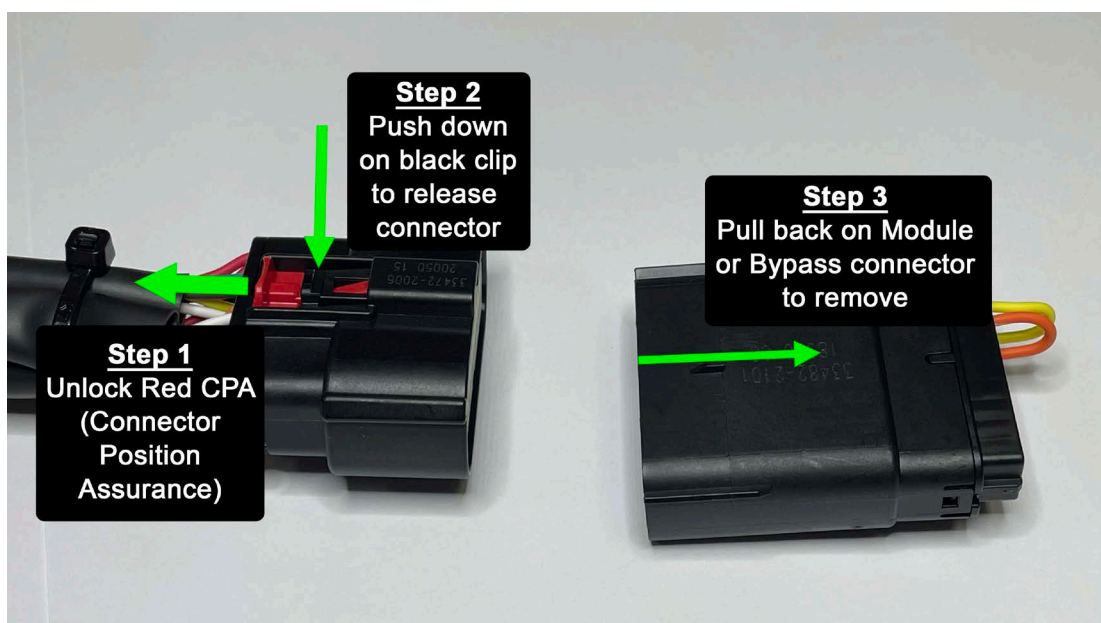

3.11. Installing the Nomad LockUp app on Apple Devices

This chapter will cover finding, downloading and confirming that the Nomad LockUp app is ready to communicate with your Nomad LockUp Module using an Apple mobile device.

The Nomad Lock-Up App is a free to download app available from the Apple App Store. You will require an Apple ID in order to download applications from the Apple App Store.

Minimum system requirements for your Apple mobile device to run the Nomad LockUp App are:

- Apple iPhone mobile digital device with iOS version 11 or later
- Apple iPad mobile digital device with iPadOS version 11 or later
- Internet Access (only required to download the application and for firmware updates)

If your Apple mobile device operating system does not meet these requirements you may not be able to download the app. Please follow the instructions provided by Apple to update your devices operating system first then try downloading the Nomad LockUp app again.

3.11.1 On your Apple device, open the **App Store** application.



3.11.2 Tap on the **Search** button at the bottom of the App Store screen.

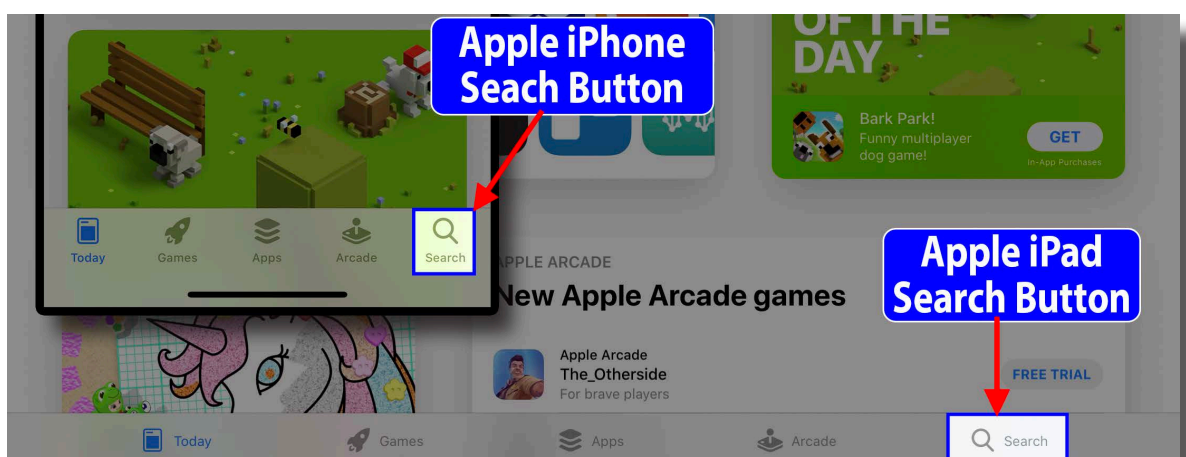

- 3.11.3 In the search field type “nomad lockup” and press enter/search. Locate the app called **Nomad LockUp** in the results and tap on ‘Get’. You may be asked to enter your Apple ID username and password.

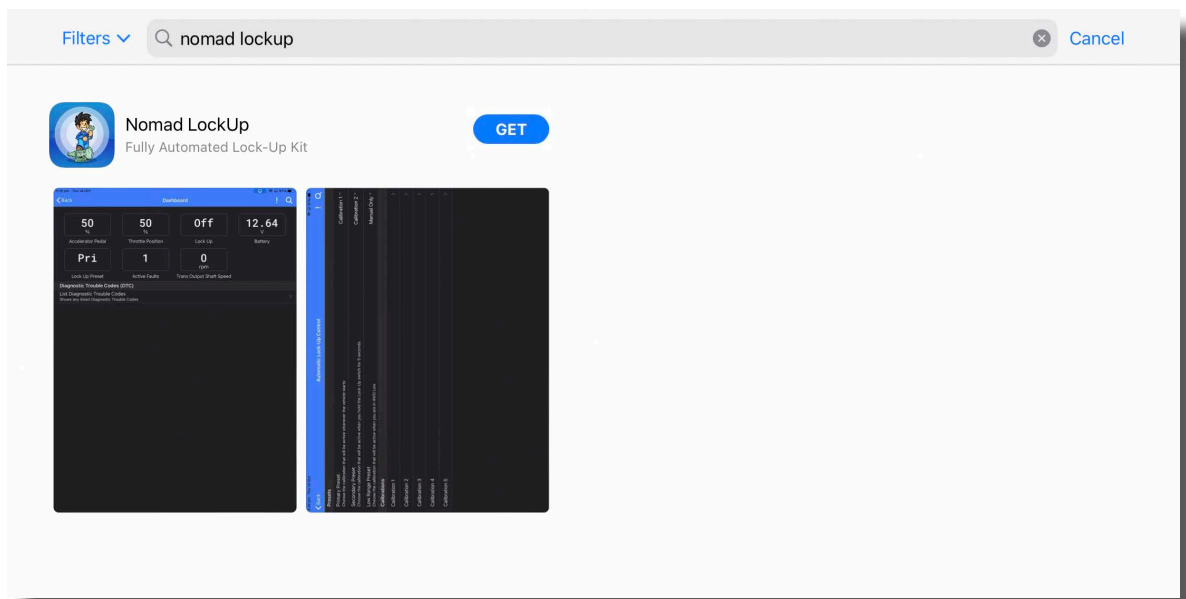

- 3.11.4 Once the app has finished downloading, tap on the icon to open. The first time you open the Nomad LockUp app it will ask permission to use the devices Bluetooth® communication system to access the Nomad Lock-Up Module. Please select OK.
- 3.11.5 The app will now search for any Nomad Lock-Up Modules within range that are powered up. If you are not in range of your Nomad Lock-Up Module or it is not powered up, then the app will only show a spinning wheel indicating that there is no module in range.

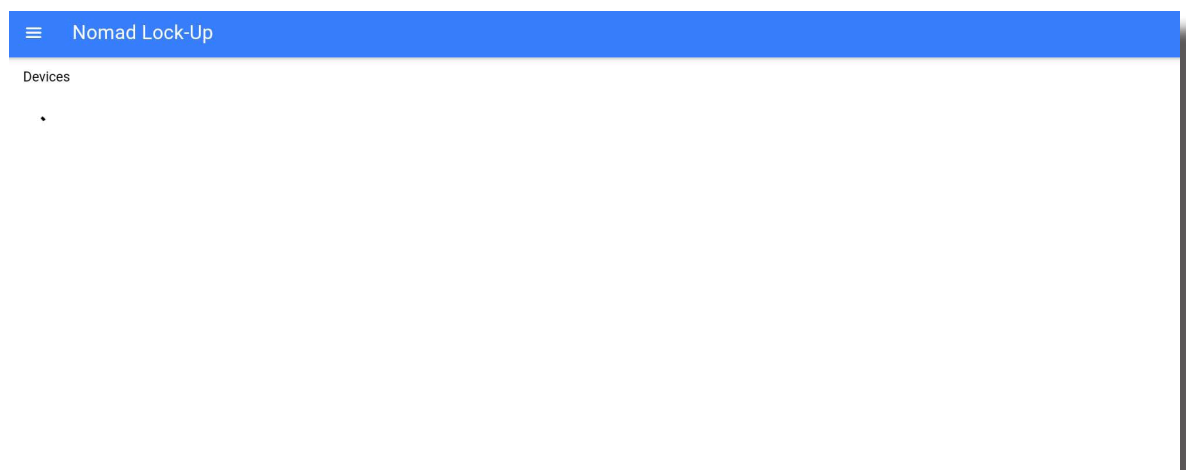

- 3.11.6 If you have reached this step then the app is installed and ready to connect to your Nomad Lock-Up Module. You can now skip to step 4.

3.12. Troubleshooting Installation on Apple Devices

This chapter will cover some basic troubleshooting steps you can follow if you have not been able to connect your Apple device to the Nomad Lock-Up module.

- 3.12.1 If the app says '**! Bluetooth is disabled**' then it means that the Bluetooth communication in your smart device is not set up correctly. Most commonly this is due to the Bluetooth being turned off completely or it could be that the Nomad LockUp app has not been authorised to use Bluetooth yet.
- 3.12.2 First, close the app down and then quit the app by swiping up from the bottom or double pressing the home button and then swipe up on the app. Re-open the app. If the '**! Bluetooth is disabled**' message still remains continue to the next step.

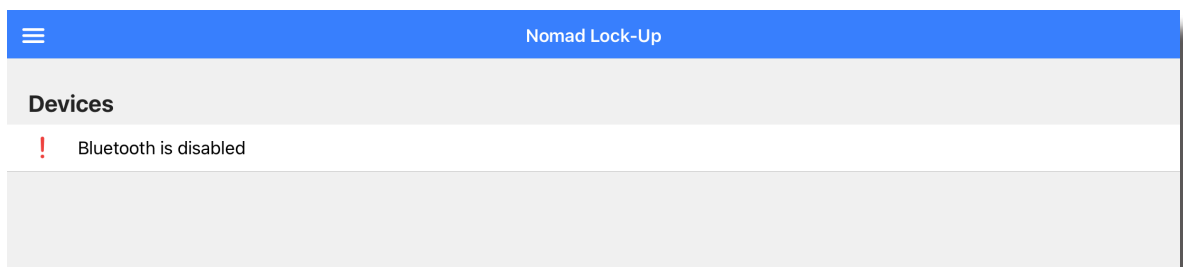

- 3.12.3 Open the Settings app and select Bluetooth. If Bluetooth is switched off, please turn it on. Close the settings app and re-open the Nomad LockUp app. You should no longer see the '**! Bluetooth is disabled**' message, instead it should be replaced with the spinning wheel.

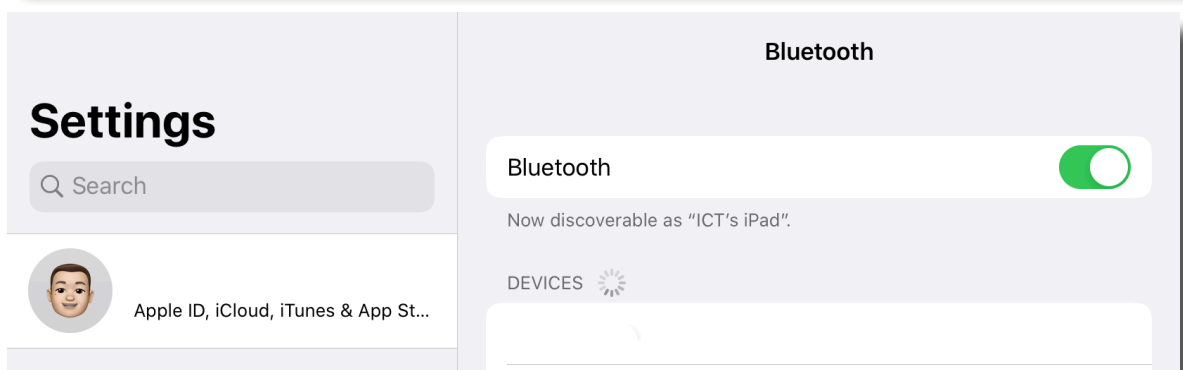
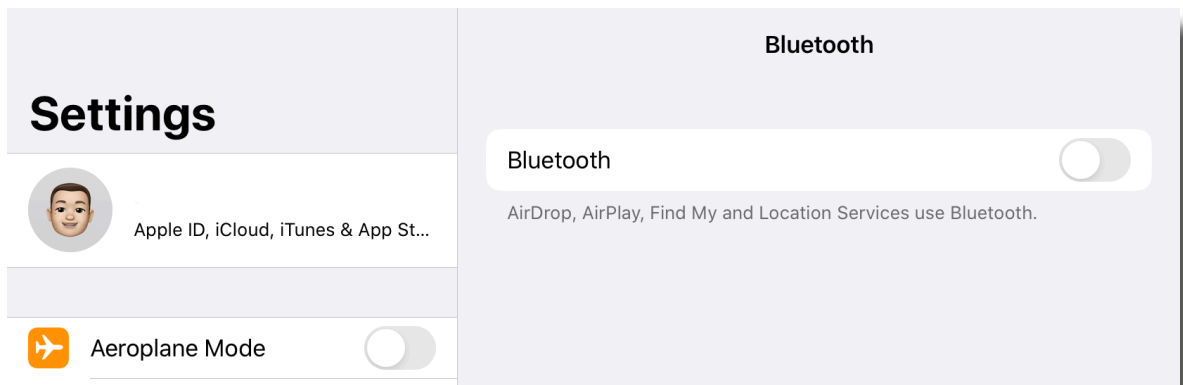

- 3.12.4 If you are still seeing the '**! Bluetooth is disabled**' message, open the Settings app and scroll down the menu to Nomad LockUp. Tap on Nomad LockUp and verify that the Bluetooth access is enabled for the app. If not, switch access on. Return to the Nomad Lock-Up app and check you are no longer seeing the '**! Bluetooth is disabled**' message, instead you should be seeing the spinning wheel.

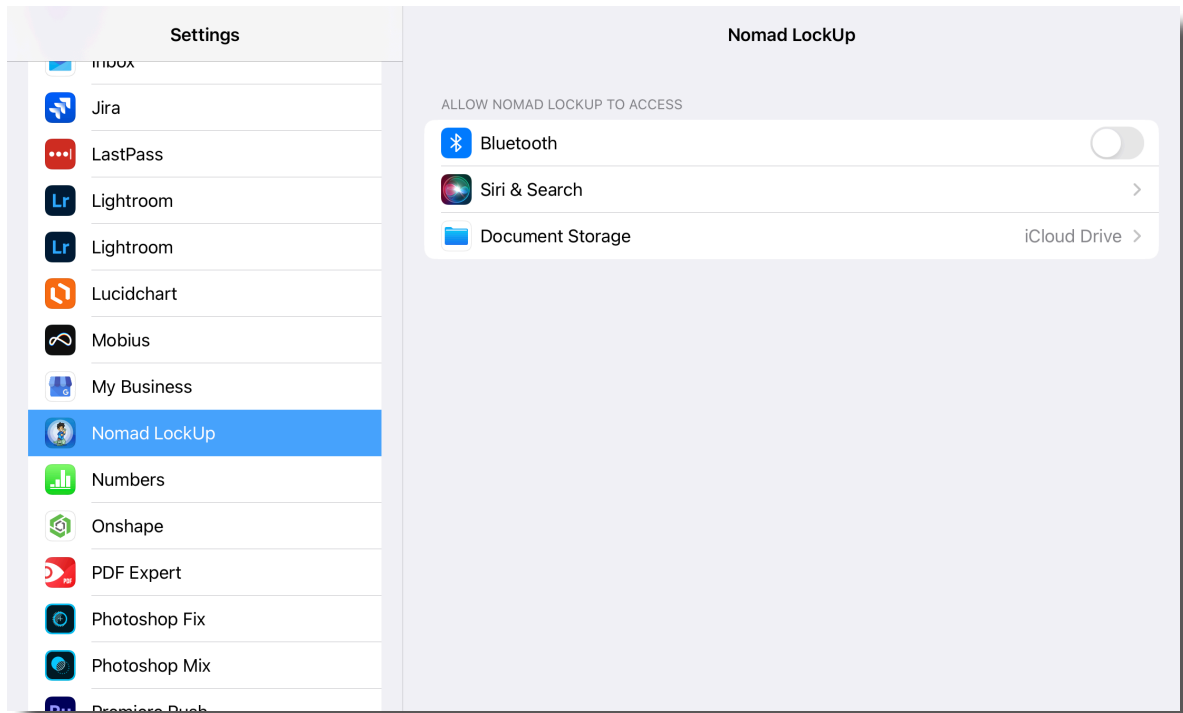

- 3.12.5 If none of these items have worked, please close the app. Tap and hold on the Nomad Lock-Up app icon and select Delete app. Then power your device off and reboot. Start from the beginning and download the app again. Make sure you allow the app all the permissions it requests.
- 3.12.6 If you are still unable to get rid of the '**! Bluetooth is Disabled**' message please contact Wholesale Automatic Transmissions for further assistance.

3.13. Installing the Nomad LockUp app on Android™ Devices

This chapter will cover finding, downloading and confirming that the Nomad LockUp app is ready to communicate with your Nomad Lock-Up Module using an Android mobile device.

The Nomad LockUp app is a free to download app available from the Google Play Store. You will require a Google Account in order to download applications from the Google Play Store.

Minimum system requirements for your Android mobile device to run the Nomad LockUp app are:

- Android operating system version 4.4 or later
- Internet access (only required to download the application and for firmware updates)

If your Android mobile device operating system does not meet these requirements you may not be able to download the app. Please follow the instructions provided by your device manufacturer to update your devices operating system first then try downloading the Nomad LockUp app again.

If the operating system on your Android mobile device is unable to be updated to a compatible version you will need to locate an alternative smart device that does meet the requirements.

- 3.13.1 On your Android device, open the **Google Play Store** application. Tap on the **Search** field at the top of the Google Play Store screen and type “nomad lockup”. Tap on the Nomad LockUp app to show the app page.

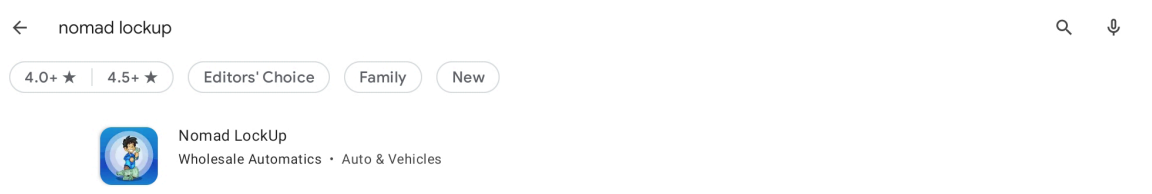

- 3.13.2 On the app page, tap on Install to download and install the app.

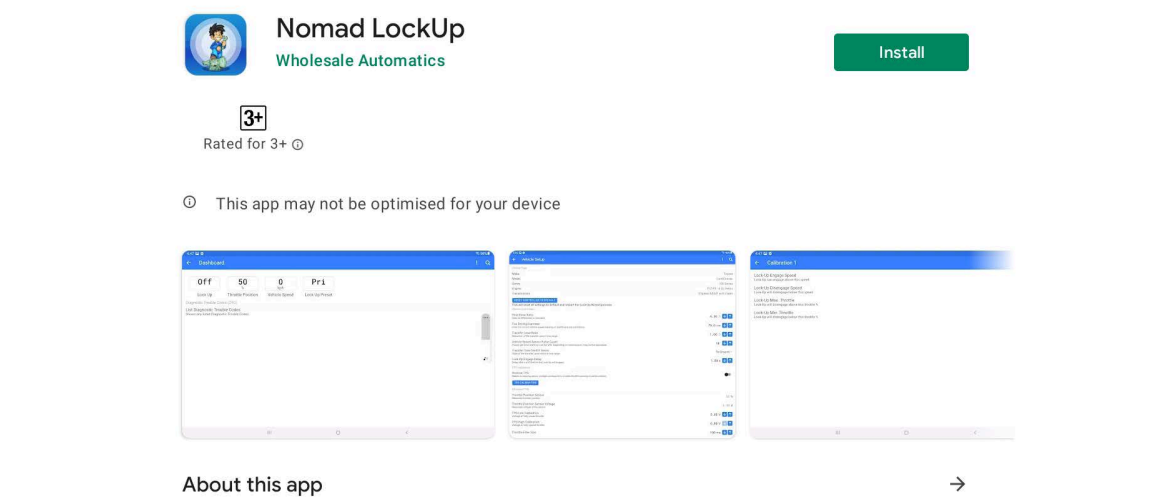

3.13.3 When the app opens for the first time you will be asked for permission for the app to access the devices location. Tap on 'While using the app' to continue. This permission is required for the Bluetooth functionality.

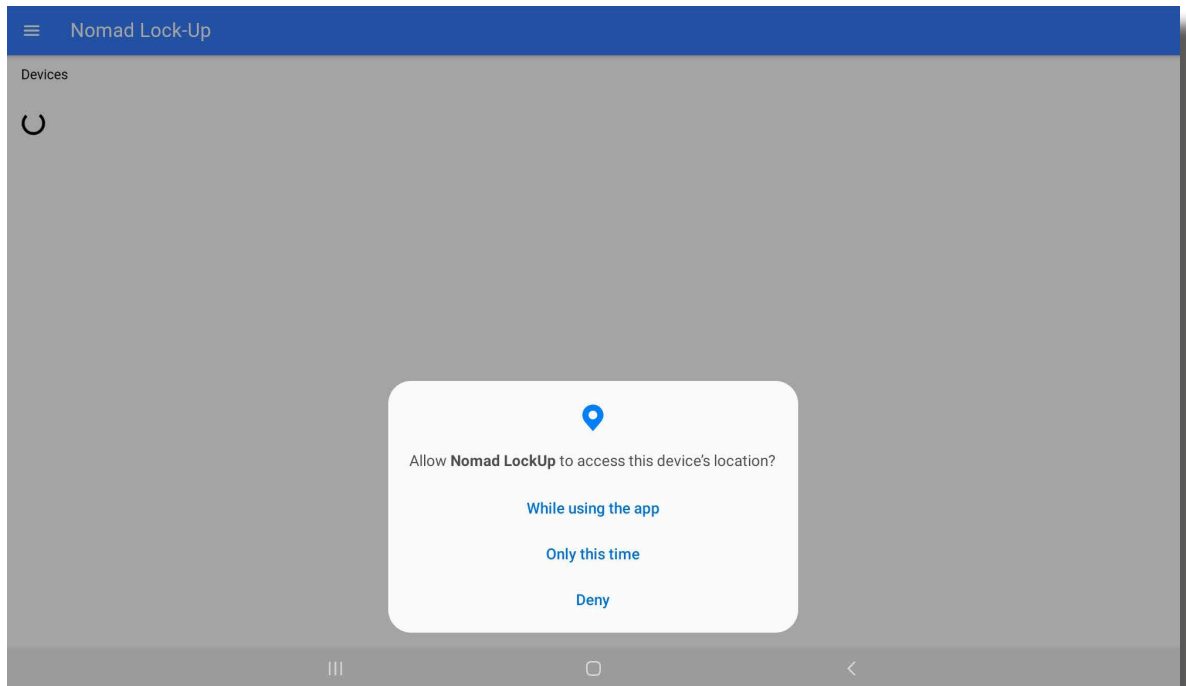

3.13.4 You should now see the devices page and a list of any Nomad Lock-Up Modules that are powered up and within range. If you are not in range of your Nomad Lock-Up Module or it is not powered up then the app will only show a spinning wheel indicating that there is no module in range.

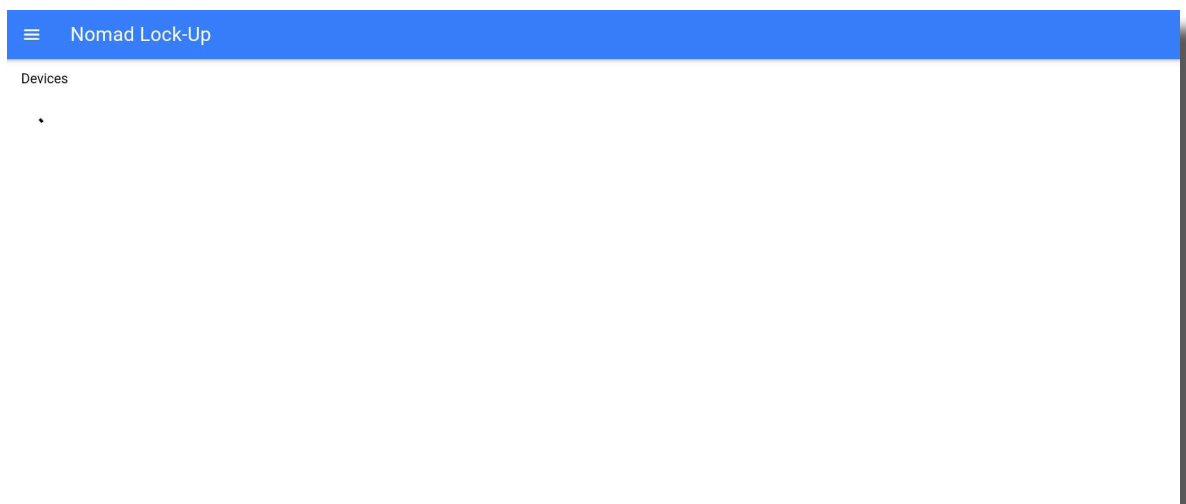

3.13.5 If you have reached this step the app is installed and ready to connect to your Nomad Lock-Up Module. You can now skip to step 4.

3.14. Troubleshooting Installation on Android Devices

This chapter will cover some basic troubleshooting steps you can follow if you have not been able to connect your Android device to the Nomad Lock-Up module.

3.14.1 If the app says '**! Bluetooth is Disabled**' then it means that the Bluetooth communication in your smart device is not set up correctly. This could be because your app did not recognise that it has access to your Bluetooth system, Bluetooth is turned off completely or it could be that the Nomad LockUp app does not have the required Bluetooth permissions.

3.14.2 First, close the app and close it from the multitasking menu. Re-open the app. If the '**! Bluetooth is Disabled**' message still remains continue to the next step.

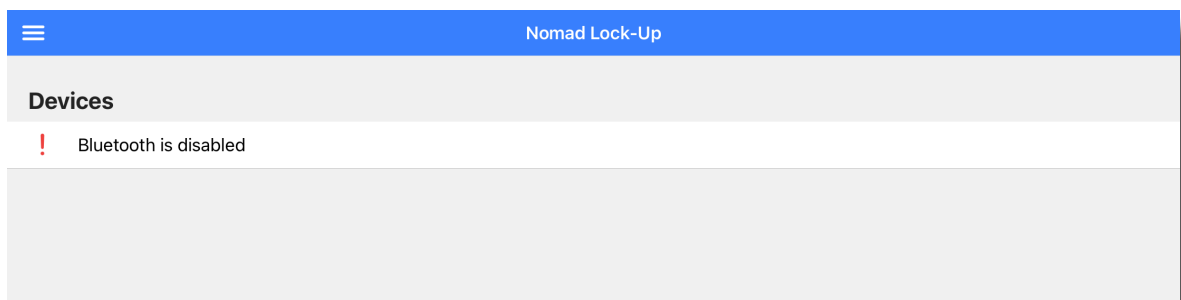

3.14.3 Swipe down from the top of the screen and tap on the grayed out Bluetooth icon. Close the settings window and force close the Nomad LockUp App. Re-open the Nomad LockUp app, you should no longer see the '**! Bluetooth is disabled**' message, instead it should be replaced with the spinning wheel.

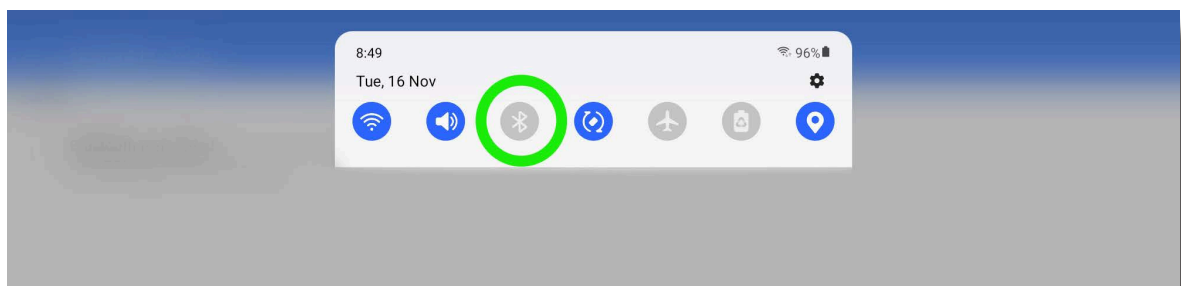

3.14.4 If you are seeing the '**Location services are disabled**' message, this means that you have locations service switch off. This service is required for the app to function correctly.

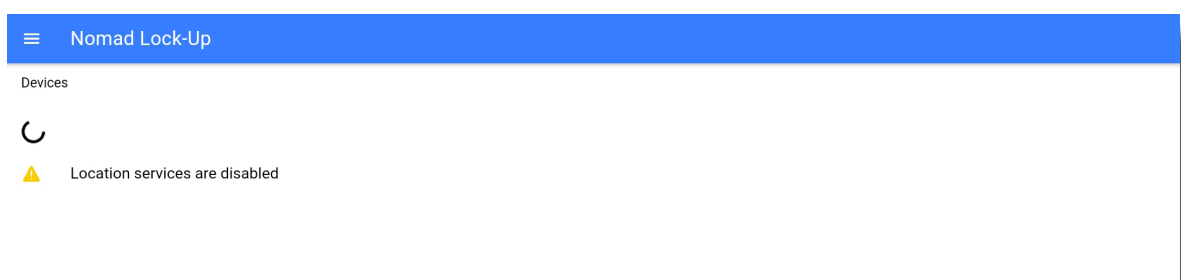

- 3.14.5 Swipe down from the top of the screen and tap on the grayed out locations icon. This will turn locations service on. Close the settings window and force close the Nomad LockUp app. Re-open the Nomad LockUp app, you should no longer see the '**Location services are disabled**' message. It instead should be replaced with the spinning wheel.

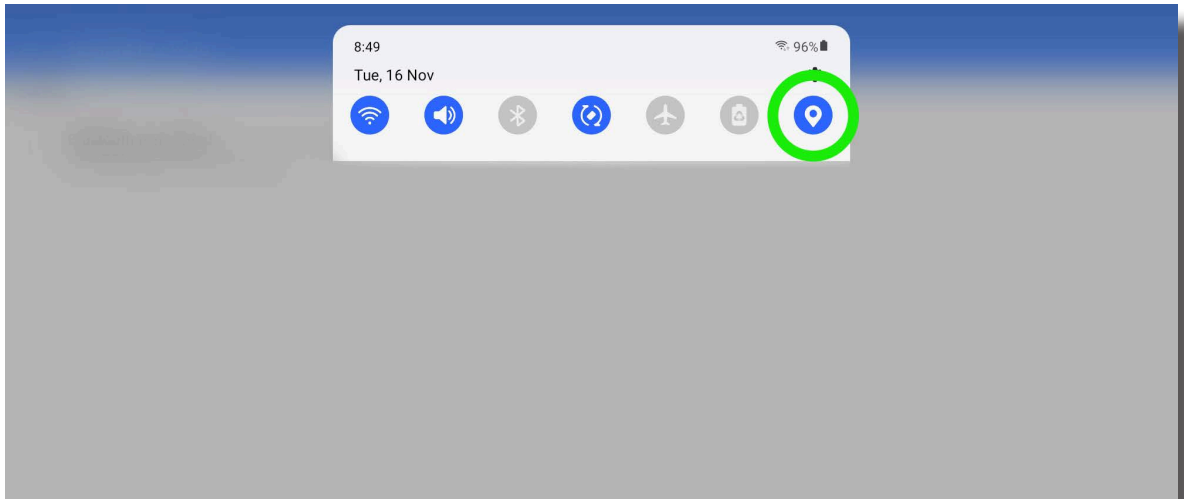

- 3.14.6 If none of these items have worked, please close the app. Tap and hold on the Nomad LockUp app icon and tap on Uninstall. Then power your device off and reboot. Start from the beginning and download the app again.
- 3.14.7 If you are still seeing the '**! Bluetooth is disabled**' message or the '**Location services are disabled**' message please contact Wholesale Automatic Transmissions for further assistance.

4. Setup Wizard

4.1. First Connection and Firmware Update

- 4.1.1 Turn your vehicle's ignition on, but do not start the engine.
- 4.1.2 Open the Nomad Lock-Up application
- 4.1.3 Tap on your Nomad Lock-Up module from the Devices list.

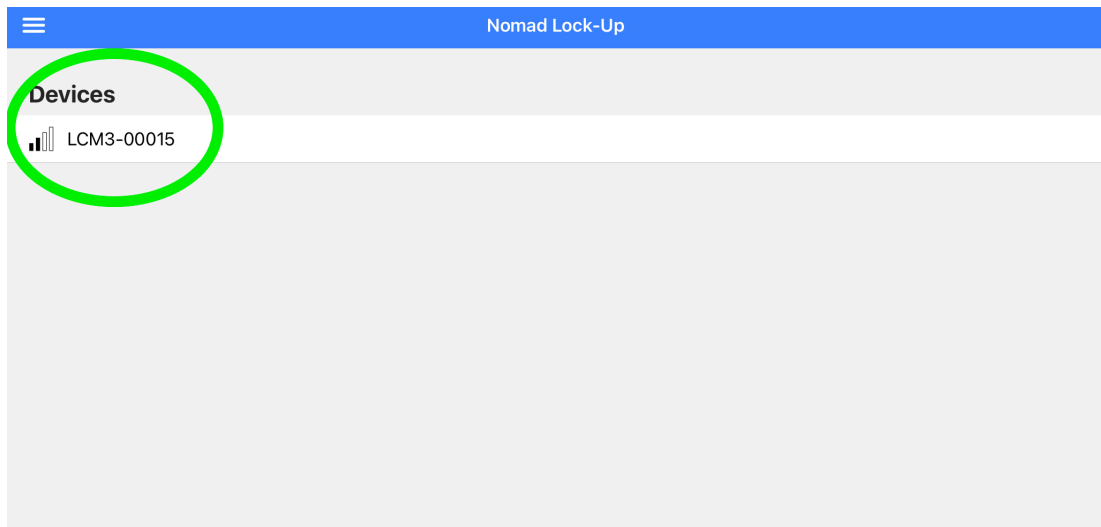

- 4.1.4 If this is the first time you have connected to your Nomad module you will be prompted to pair your device. Tap Pair.

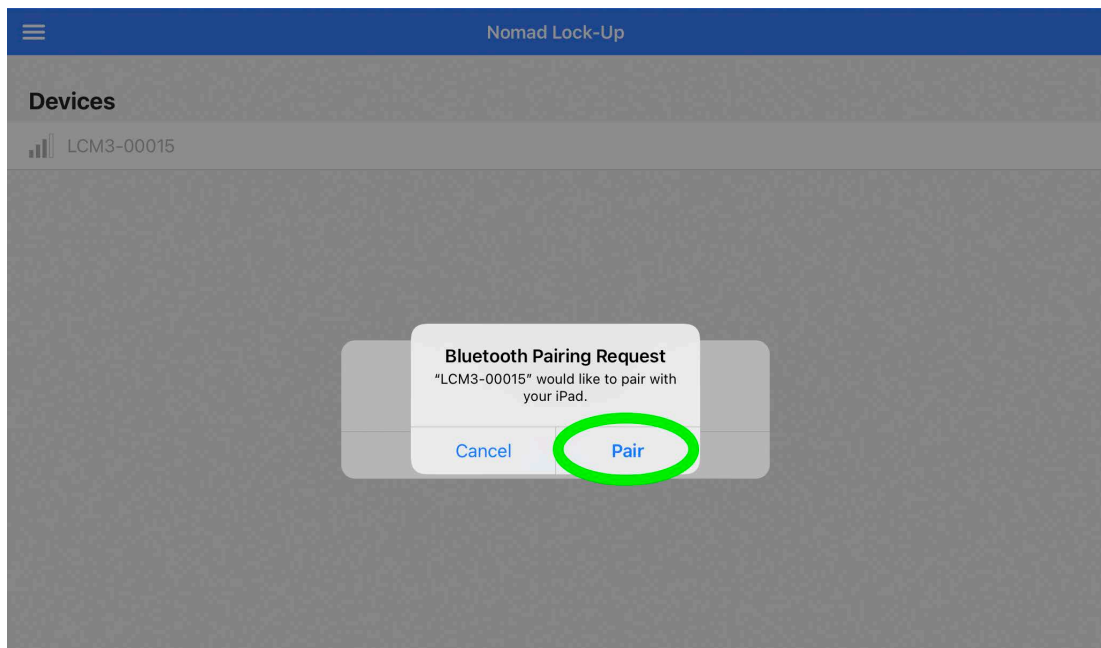

- 4.1.5 Upon initial connection the Nomad LockUp app will check if there is a new version of firmware for the module. As we develop new vehicles and add features we will provide the ability to update firmware as needed.

You will see the following prompt if there is new firmware available for your Nomad module. If your Nomad Lock-Up module is running the latest firmware, you can skip to the vehicle setup step.

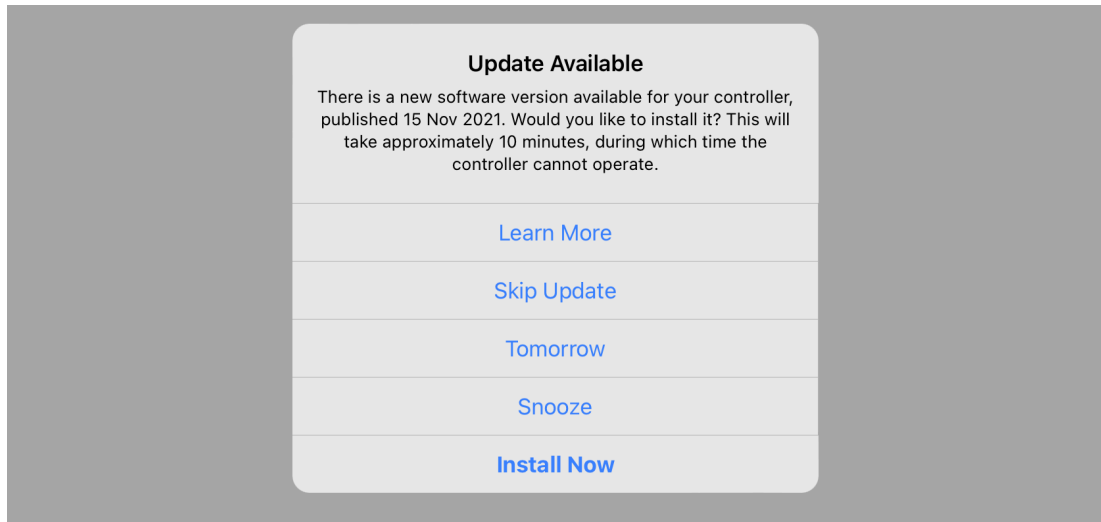

- 4.1.6 Tap on Install Now. This will take approximately 10mins to download and install the latest firmware to ensure your Nomad Lock-Up module is up to date.
- 4.1.7 Please ensure your device does not go to sleep during this process. Also if you are using a phone, do not answer a call during this process as it may cause the update to fail.

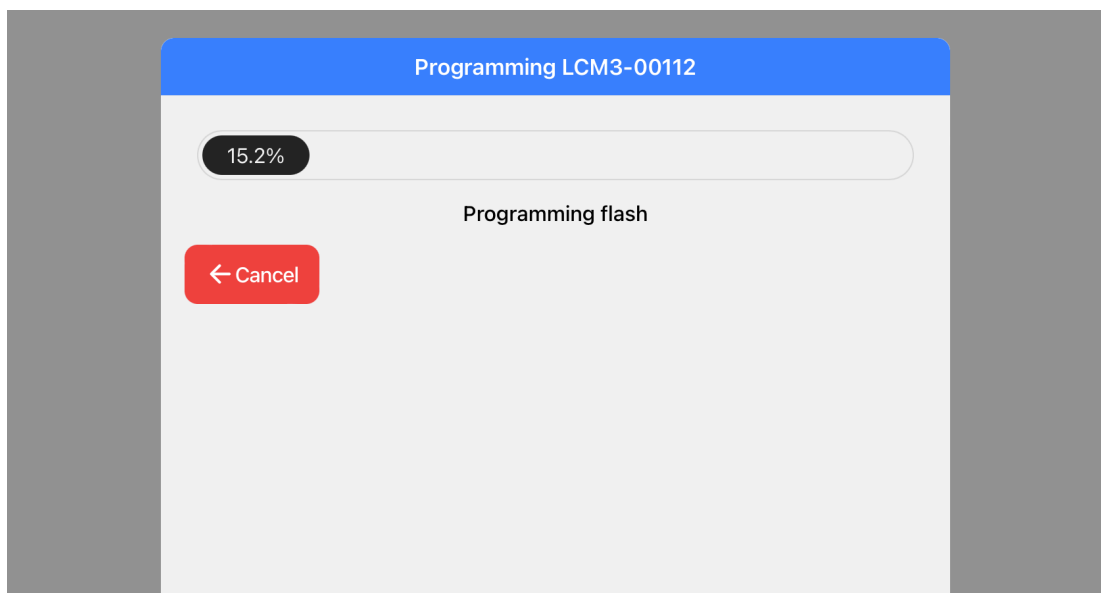

- 4.1.8 Once your modules firmware has been updated, you will be returned to the devices page. Tap on your device once more to connect.

4.2. Vehicle Configuration

- 4.2.1 The Setup Wizard will ask you to select your vehicle configuration. In some cases we may prefill the following values due to them being the only option. Select “Apply Changes and Restart” to continue.

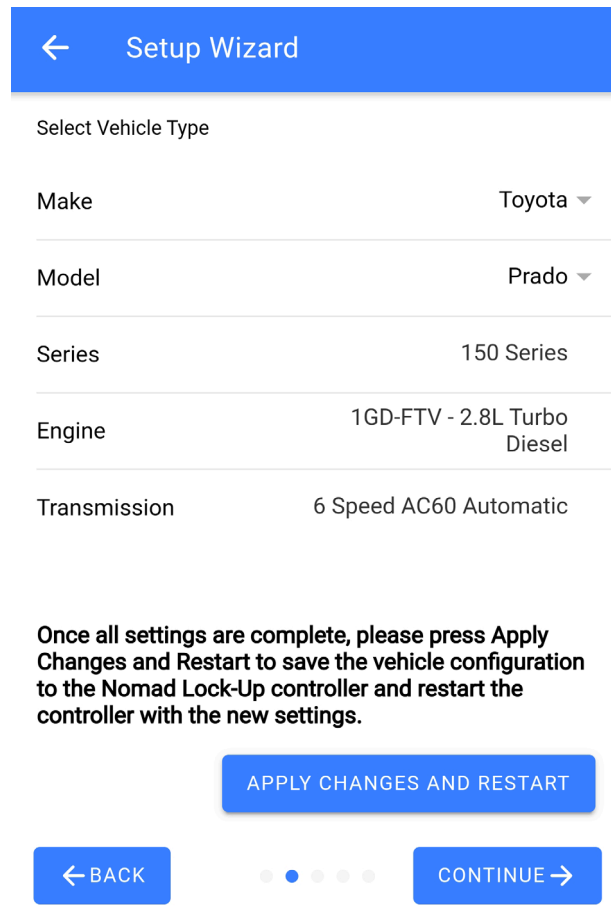

The screenshot shows a mobile application interface titled "Setup Wizard". It features a list of vehicle configuration options, each with a dropdown menu:

- Select Vehicle Type
- Make: Toyota
- Model: Prado
- Series: 150 Series
- Engine: 1GD-FTV - 2.8L Turbo Diesel
- Transmission: 6 Speed AC60 Automatic

Below the list, there is a blue button labeled "APPLY CHANGES AND RESTART". At the bottom, there are three buttons: "← BACK", a progress indicator with four dots (the second dot is filled), and "CONTINUE →".

- 4.2.2 Wait while the Nomad Lock-Up Module restarts.

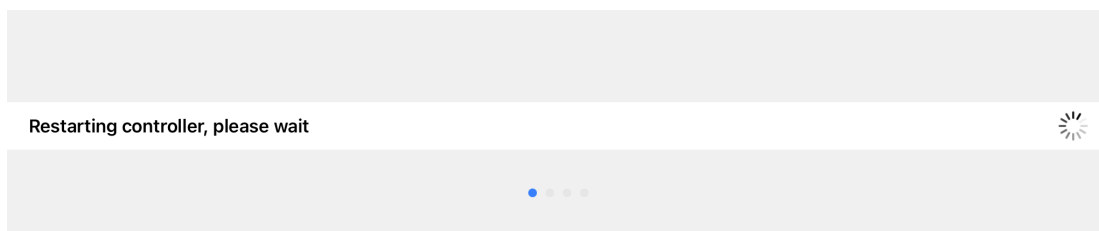

- 4.2.3 After the Nomad Lock-Up Module has rebooted tap “Continue”.

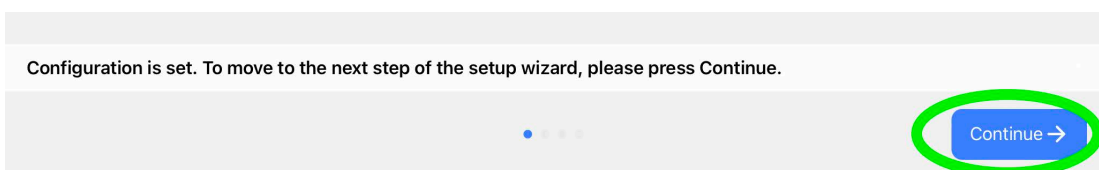

- 4.2.4 The Nomad Lock-Up Module will check for the necessary CAN bus signals that match your vehicle configuration. If the Nomad Lock-Up Module detected issues it will list the errors on the app. We recommend confirming that you have chosen the correct vehicle configuration. Also check that the CAN bus connections and the position of the two wires in the CAN bus connector are correct. You can run the test again by tapping on Try Again.

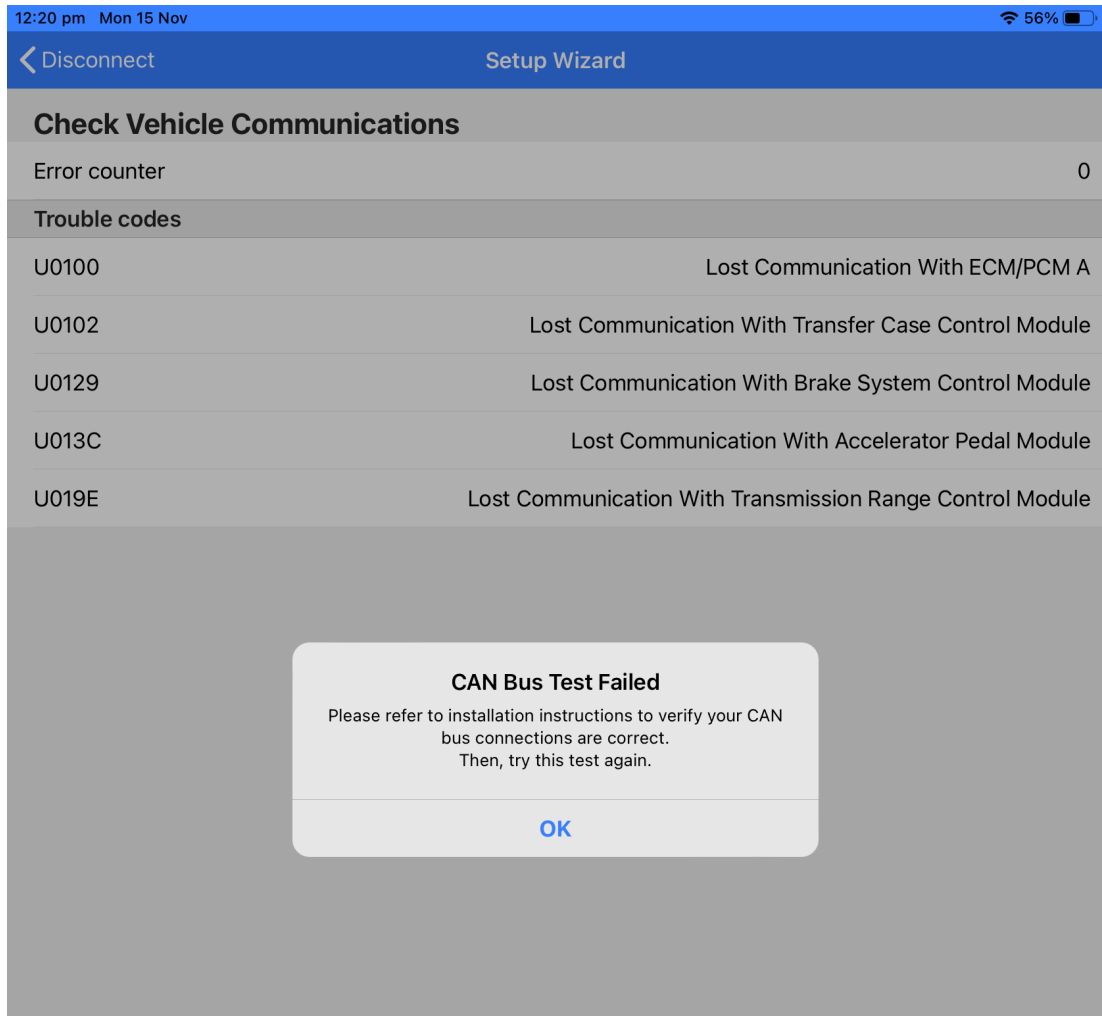

- 4.2.5 If all the CAN bus signals check out, you will see Test Passed and the continue button will be shown. Tap Continue.

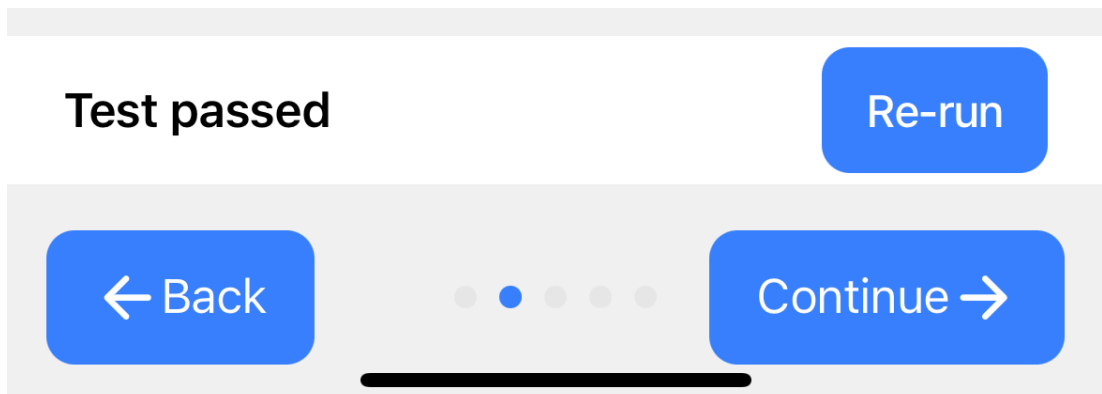

- 4.2.6 Checking Sensor Inputs allows you to verify that the signals the Nomad Lock-Up module requires to operate are being decoded correctly. These these signals with the engine off.

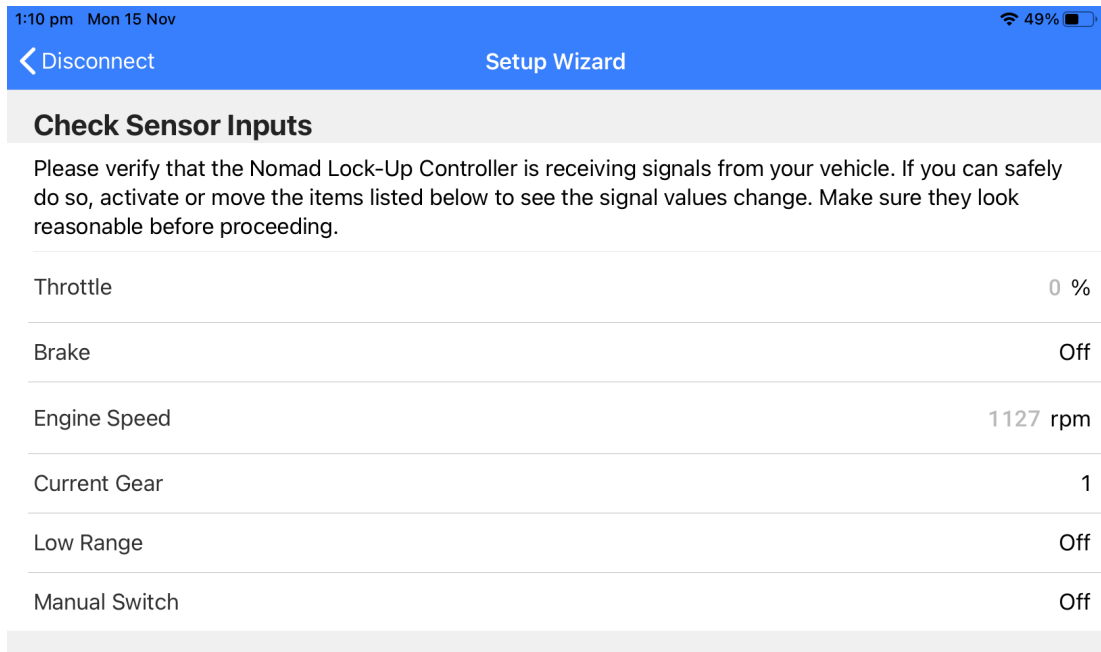

4.2.6.1 **Throttle**

Press down on the Accelerator Pedal and you should see the Throttle value increase and decrease according to the percentage of pedal movement.

4.2.6.2 **Brake**

Push down on the brake pedal to confirm we are receiving that signal.

4.2.6.3 **Engine Speed**

While you engine should be off, this should read 0. This confirms that the CAN bus signal is correct.

4.2.6.4 **Current Gear**

Move your shifter to Drive position and tap up/down to check the gear changes. You may have to press 2nd Start button in some variants.

4.2.6.5 **Low Range**

Check that the Module can detect when the vehicle is in Low Range. The Low Range value will change from "Off" to "On"

4.2.6.6 **Manual Switch**

Push the Lock-Up switch to check that the Manual Switch value will change from "Off" to "On"

4.2.7 Once all signals are confirmed, tap “Continue”.

4.2.8 Choose if you would like the Nomad Lock-Up Module to operate in Automatic or Manual Mode. Then tap continue.

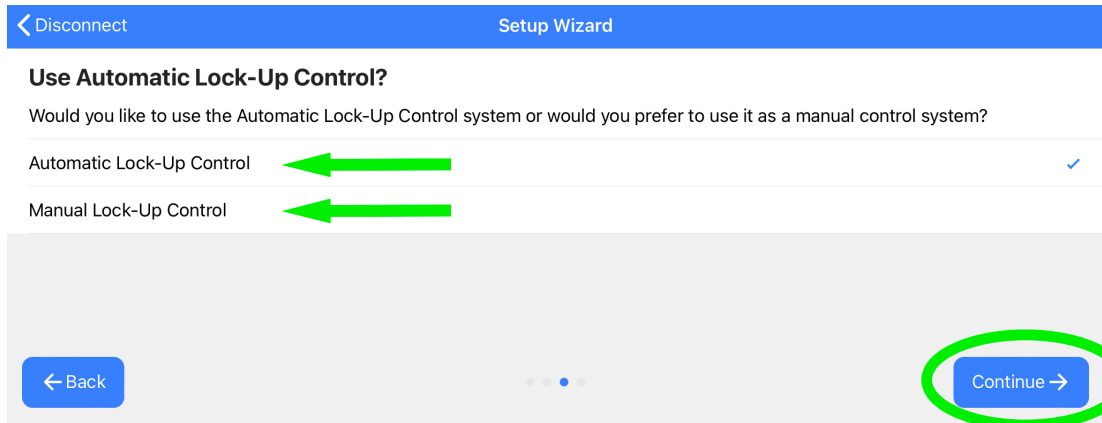

4.2.8.1 **Automatic mode**

The torque converter lock-up will automatically engage and disengage at predetermined speeds and loads that we have configured for you. These values can be modified at anytime to suit your driving style. In Low Range the lock-up is still controlled manually via the switch.

This is the recommended setting for most people.

For more information about configuring the Nomad Lock-Up system, please check out our Nomad Lock-Up Users Guide. Link below.



4.2.8.2 **Manual mode**

You decide when the lock-up is engaged by toggling lock-up on and off via the manual switch. This will make the Nomad Lock-Up Module operate the same way as our previous GEN2 Lock-Up Kit.

- 4.2.9 Please set the Rolling Tire Diameter for your vehicle. To find the Rolling Diameter measure from the ground to the centre of the axle, then double this measurement and enter it into the app.

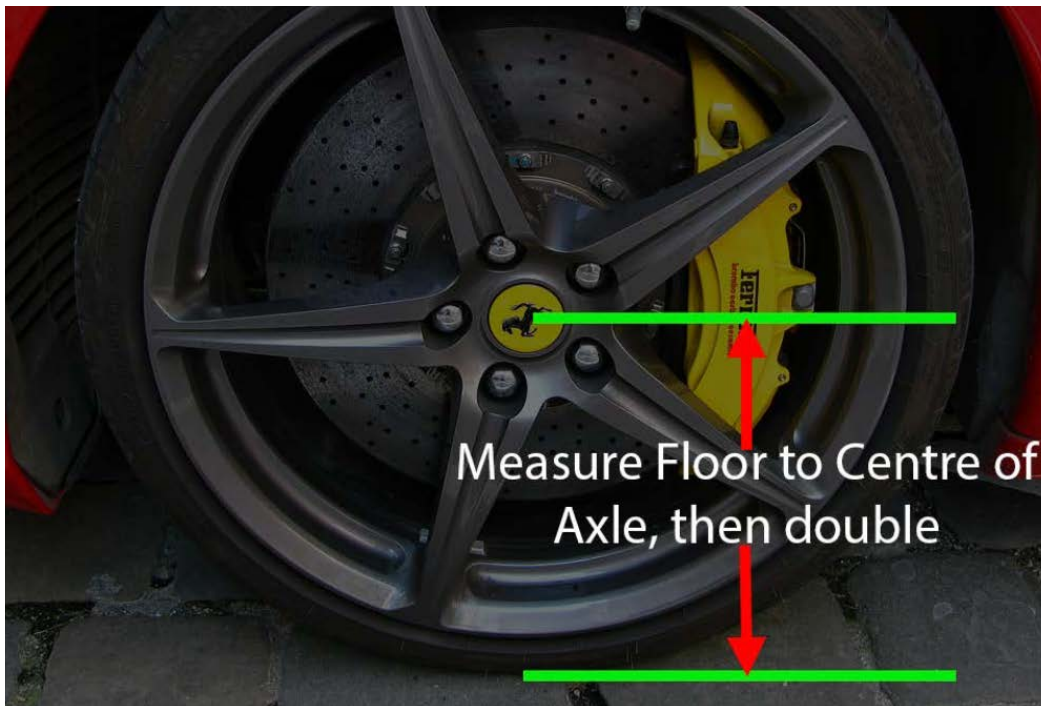
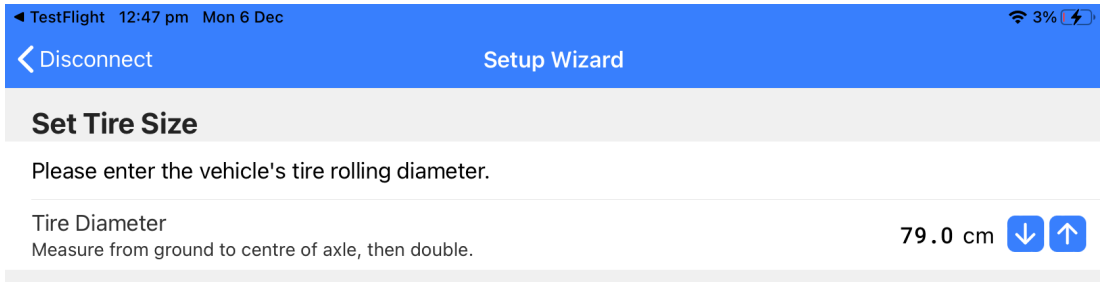

- 4.2.10 Tap "Finish" to complete the Setup Wizard

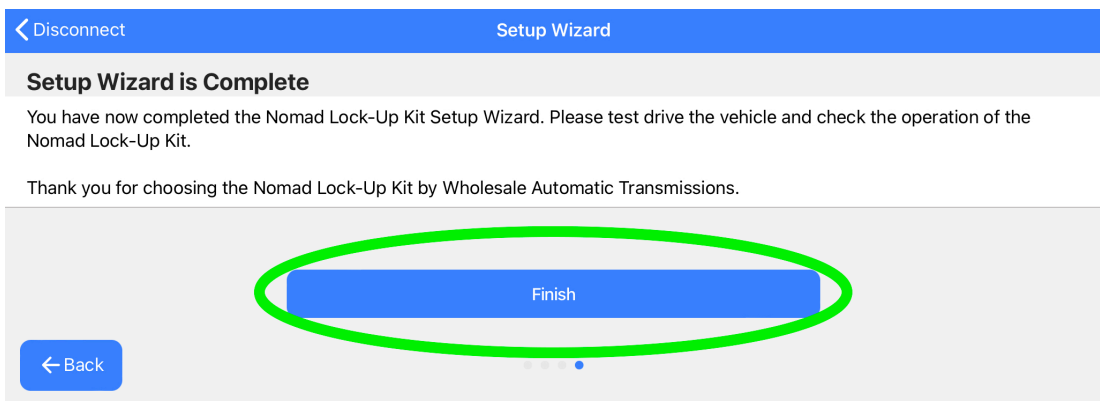

- 4.2.11 Turn your ignition off and then back on again to power cycle the Nomad module.

- 4.2.12 Allow time for the app to reconnect to the Nomad Lock-Up Module. Confirm there are no DTCs (Diagnostic Trouble Codes) set. If you see the tick at the top right, you have completed the installation.

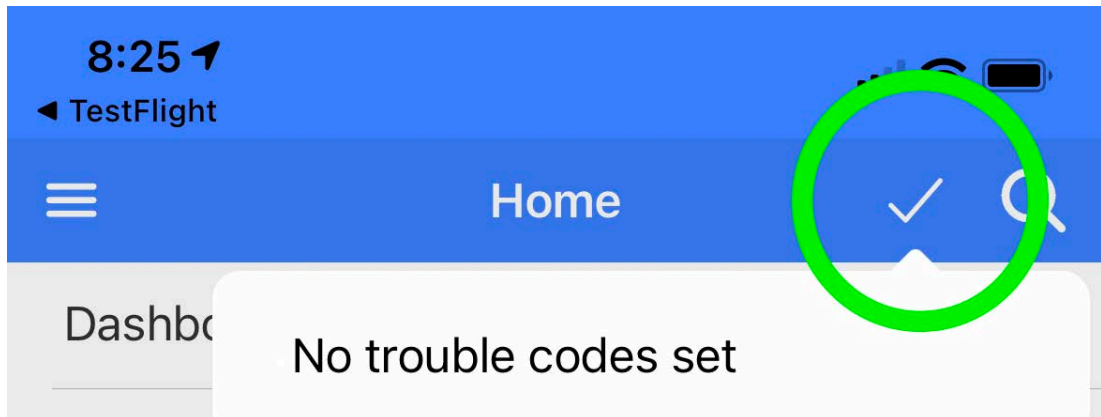

- 4.2.13 You can now take the vehicle for a test drive to confirm the Nomad Lock-Up kit is operating as expected. At this point, we recommend re-installing any dash panels or parts removed during the installation process of the Nomad Lockup Module.
- 4.2.14 After the test drive, before switching off the vehicle, connect to the Nomad Lock-Up Module with the app to confirm you still see the tick at the top right.

Apple, Apple ID, App Store, iOS and iPadOS are a trademark of Apple Inc, registered in the U.S. and other countries and regions.

Android is a trademark of Google LLC.

The Bluetooth® word mark and logos are registered trademarks owned by Bluetooth SIG, Inc, and any use of such marks by Wholesale Automatic Transmission is under license. Other trademarks and trade names are those of their respective owners.

This completes the Installation of the Nomad Lock-Up Kit

If you would like further information
on how to adjust all of the
calibration settings, please see
User Guide documentation on our
website using the QR code below or
tapping on the QR code.



Please provide us with feedback

If you have a minute to provide us with some feedback about your experience with Wholesale Automatic Transmissions and our products, that would be greatly appreciated.

Using your device's camera app to scan the QR code below. This will take you straight to our feedback page for you to choose the most appropriate feedback method.

